



# sinamics

# G110

SINAMICS G110

**SIEMENS**

## SINAMICS G110 Documentation

---

### Getting Started Guide

The Getting Started Guide is designed to give the user quick access to all the basic information required to install and set-up the SINAMICS G110 for operation.

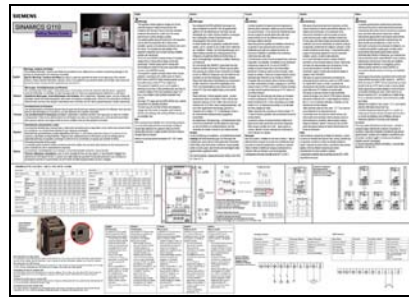

### Operating Instructions

Gives information regarding the features of SINAMICS G110 including Installation, Commissioning, Control modes, System Parameter structure, Troubleshooting, Specifications and available options for the inverter.



### Parameter List

The Parameter List contains a detailed description of all Parameters relating to the SINAMICS G110 and is structured in numerical order.



### Catalogues

In the catalogue you will find all the necessary information to select an appropriate inverter, as well as the Basic Operator Panel and Communication Options for the SINAMICS G110 series.

---

# SIEMENS

## SINAMICS G110 120 W - 3 kW

Operating Instructions  
User Documentation

*Inverter Type*  
**SINAMICS G110**

*Firmware Version*  
**1.0 & 1.1**  
(See Page 4)

Issue 04/2005

<b>Overview</b>	<b>1</b>
<b>Installation</b>	<b>2</b>
<b>Commissioning</b>	<b>3</b>
<b>Using the SINAMICS G110</b>	<b>4</b>
<b>System Parameters</b>	<b>5</b>
<b>Troubleshooting</b>	<b>6</b>
<b>Specifications</b>	<b>7</b>
<b>Options</b>	<b>8</b>
<b>Electro-Magnetic Compatibility</b>	<b>9</b>
<b>Appendices</b>	<b>A B C D E F</b>
<b>Index</b>	

## Summary of Amendments

Edition	Valid for firmware version	Status/Changes	Order no of the inverter 6SL3211-0xxxx-xxxx
04/2003	1.0	First issue	Last digit "0" 6SL3211-0xxxx-xxx0
11/2004	1.0  1.1	New features inserted: Types of Control using the Terminals (2 wire/3 wire control) 4.3.4 Parameter P1234 in DC braking 4.3.5 Compound braking	Last digit "0" 6SL3211-0xxxx-xxx0  Last digit "1" 6SL3211-0xxxx-xxx1
04/2005		6.1 Troubleshooting with Standard Inverter LED - timings of LED has been updated.	

Approved Siemens Quality for Software and Training is to DIN ISO 14001, Reg. No. 2160-01

The reproduction, transmission or use of this document, or its contents is not permitted unless authorized in writing. Offenders will be liable for damages. All rights including rights created by patent grant or registration of a utility model or design are reserved.

© Siemens AG 2005. All Rights Reserved.

SINAMICS® is a registered trademark of Siemens.

Order Number. 6SL3298-0AA11-0BP0  
Printed on demand in Fürth, Germany

Other functions not described in this document may be available. However, this fact shall not constitute an obligation to supply such functions with a new control, or when servicing.

We have checked that the contents of this document correspond to the hardware and software described. There may be discrepancies nevertheless, and no guarantee can be given that they are completely identical. The information contained in this document is reviewed regularly and any necessary changes will be included in the next edition. We welcome suggestions for improvement.

Siemens handbooks are printed on chlorine-free paper that has been produced from managed sustainable forests. No solvents have been used in the printing or binding process.

Document subject to change without prior notice.

Siemens-Aktiengesellschaft.

## Important Information



---

**WARNING**

Before installing and commissioning the inverter, you must read all safety instructions and warnings carefully including all the warning labels attached to the equipment. Make sure that the warning labels are kept in a legible condition.

---

**Use for intended purpose only**

The equipment may be used only for the application stated in the manual and only in conjunction with devices and components recommended and authorized by Siemens.

**Information is also available from:****Technical Support Nuremberg**

Tel: +49 (0) 180 5050 222

Fax: +49 (0) 180 5050 223

Email: [adsupport@siemens.com](mailto:adsupport@siemens.com)

Monday to Friday: 7:00 am to 5:00 pm (local time)

**Internet Home Address**

Customers can access technical and general information at:

<http://www.siemens.de/sinamics-g110>

**Contact address**

Should any questions or problems arise while reading this manual, please contact the Siemens office concerned using the form provided at the back this manual.

## Definitions



---

### **DANGER**

For the purpose of this documentation and the product warning labels, "Danger" indicates an imminently hazardous situation which, if not avoided, will result in death or serious injury.

---



---

### **WARNING**

For the purpose of this documentation and the product warning labels, "Warning" indicates a potentially hazardous situation which, if not avoided, could result in death or serious injury.

---



---

### **CAUTION**

Used in conjunction with the safety alert symbol indicates a potentially hazardous situation which, if not avoided, may result in minor or moderate injury.

---



---

### **CAUTION**

Used without the safety alert symbol indicates a potentially hazardous situation which, if not avoided, may result in property damage.

---



---

### **NOTICE**

Indicates a potential situation which, if not avoided, may result in an undesirable result or state.

---



---

### **NOTE**

For the purpose of this documentation, "Note" indicates important information relating to the product or highlights part of the documentation for special attention.

---



---

### **Qualified personnel**

For the purpose of this Instruction Manual and product labels, a "Qualified person" is someone who is familiar with the installation, mounting, start-up and operation of the equipment and the hazards involved.

He or she must have the following qualifications:

1. Trained and authorized to energize, de-energize, clear, ground and tag circuits and equipment in accordance with established safety procedures.
  2. Trained in the proper care and use of protective equipment in accordance with established safety procedures.
  3. Trained in rendering first aid.
- 



- PE – Protective Earth uses circuit protective conductors sized for short circuits where the voltage will not rise in excess of 50 volts. This connection is normally used to ground the inverter.
  -  - Is the ground connection where the reference voltage can be the same as the Earth voltage. This connection is normally used to ground the motor.
-

## Safety Instructions

The following Warnings, Cautions and Notes are provided for your safety and as a means of preventing damage to the product or components in the machines connected. This section lists Warnings, Cautions and Notes, which apply generally when handling SINAMICS G110 Inverters, classified as **General, Transport & Storage, Commissioning, Operation, Repair and Dismantling & Disposal**.

**Specific Warnings, Cautions and Notes** that apply to particular activities are listed at the beginning of the relevant chapters and are repeated or supplemented at critical points throughout these sections.

**Please read the information carefully, since it is provided for your personal safety and will also help prolong the service life of your SINAMICS G110 Inverter and the equipment you connect to it.**

### General



---

#### WARNINGS

- This equipment contains dangerous voltages and controls potentially dangerous rotating mechanical parts. Non-compliance with **Warnings** or failure to follow the instructions contained in this manual can result in loss of life, severe personal injury or serious damage to property.
- Only suitable qualified personnel should work on this equipment, and only after becoming familiar with all safety notices, installation, operation and maintenance procedures contained in this manual. The successful and safe operation of this equipment is dependent upon its proper handling, installation, operation and maintenance.
- Risk of electric shock. The DC link capacitors remain charged for five minutes after power has been removed. **The equipment SHOULD NOT be opened until 5 minutes after the power has been removed.**
- The horsepower (hp) ratings used throughout this document are obtained by comparison to the Siemens 1LA6 and 1LA7 motors and not NEMA/UL rated motors.



---

#### CAUTION

- Children and the general public must be prevented from accessing or approaching the equipment!
- This equipment may only be used for the purpose specified by the manufacturer. Unauthorized modifications and the use of spare parts and accessories that are not sold or recommended by the manufacturer of the equipment can cause fires, electric shocks and injuries.

---

#### NOTES

- Keep these operating instructions within easy reach of the equipment and make them available to all users
  - Whenever measuring or testing has to be performed on live equipment, the regulations of Safety Code VBG 4.0 must be observed, in particular §8 "Permissible Deviations when Working on Live Parts". Suitable electronic tools should be used.
  - Before installing and commissioning, please read these safety instructions and warnings carefully and all the warning labels attached to the equipment. Make sure that the warning labels on the inverter are kept in a legible condition.
-

## Transport & Storage

---



### WARNING

Correct transport, storage, erection and mounting, as well as careful operation and maintenance are essential for proper and safe operation of the equipment.

---



### CAUTION

Protect the inverter against physical shocks and vibration during transport and storage. Also be sure to protect it against water (rainfall) and excessive temperatures (see Section 2.3 on page 18).

---

## Commissioning

---



### WARNINGS

- Work on the device/system by **unqualified** personnel or failure to comply with warnings can result in severe personal injury or serious damage to material. Only suitably qualified personnel trained in the setup, installation, commissioning and operation of the product should carry out work on the device/system.
  - Only permanently-wired input power connections are allowed. This equipment must be grounded (IEC 536 Class 1, NEC and other applicable standards).
  - If a Residual Current-operated protective Device (RCD) is to be used, it must be an RCD type B. However, if the SINAMICS G110 inverter is connected to a single-phase grounded-neutral star mains network, an RCD of type A is permissible.
  - The following terminals can carry dangerous voltages even if the inverter is inoperative:
    - ◆ the power supply terminals L1 and L2/N.
    - ◆ the motor terminals U, V, W and the terminals DC+ and DC-.
  - This equipment must not be used as an 'emergency stop mechanism' (see EN 60204, 9.2.5.4)
- 



### CAUTION

The connection of power, motor and control cables to the inverter must be carried out as shown in Figure 2-8 on page 28, to prevent inductive and capacitive interference from affecting the correct functioning of the inverter.

---



## Operation



### WARNINGS

- SINAMICS G110 inverters operate at high voltages.
- When operating electrical devices, it is impossible to avoid applying hazardous voltages to certain parts of the equipment.
- Emergency Stop facilities according to EN 60204 IEC 204 (VDE 0113) must remain operative in all operating modes of the control equipment. Any disengagement of the Emergency Stop facility must not lead to uncontrolled or undefined restart.
- Wherever faults occurring in the control equipment can lead to substantial material damage or even grievous bodily injury (i.e. potentially dangerous faults), additional external precautions must be taken or facilities provided to ensure or enforce safe operation, even when a fault occurs (e.g. independent limit switches, mechanical interlocks, etc.).
- Certain parameter settings may cause the inverter to restart automatically after an input power failure.
- Motor parameters must be accurately configured for motor overload protection to operate correctly above 5 Hz.
- This equipment is capable of providing internal motor overload protection in accordance with UL508C. Refer to P0610 and P0335, I<sup>2</sup>t is ON by default.
- This equipment is suitable for use in a circuit capable of delivering not more than 10,000 symmetrical amperes (rms), for a maximum voltage of 230 V when protected by an H or K type fuse, a circuit breaker or self-protected combination motor controller.
- This equipment must not be used as an 'emergency stop mechanism' (see EN 60204, 9.2.5.4)

## Repair



### WARNINGS

- Repairs on equipment may only be carried out by **Siemens Service**, by repair centers **authorized by Siemens** or by qualified personnel who are thoroughly acquainted with all the warnings and operating procedures contained in this manual.
- Any defective parts or components must be replaced using genuine Siemens authorized parts.
- Risk of electric shock. Wait 5 minutes for the DC capacitors to discharge before carrying out any installation work.

## Dismantling & Disposal

### NOTES

- The inverter's packaging is re-usable. Retain the packaging for future use or return it to the manufacturer.
- Easy-to-release screw and snap connectors allow you to break the unit down into its component parts. You can then re-cycle these component parts, dispose of them in **accordance with local requirements or return them to the manufacturer.**



## Table of Contents

<b>1</b>	<b>Overview .....</b>	<b>15</b>
1.1	The SINAMICS G110 .....	15
1.2	Features .....	15
<b>2</b>	<b>Installation .....</b>	<b>17</b>
2.1	General .....	17
2.2	Power Losses .....	18
2.3	Ambient operating conditions .....	18
2.4	Harmonic Currents .....	19
2.5	Derating with Pulse Frequencies .....	19
2.6	Overvoltage and Trip Levels .....	19
2.7	Overcurrent Trip Levels .....	19
2.8	Mechanical Installation .....	20
2.9	Electrical Installation .....	23
2.10	SINAMICS G110 Flat Plate Variant .....	29
<b>3</b>	<b>Commissioning .....</b>	<b>31</b>
3.1	Block Diagram .....	32
3.2	Commission Modes .....	33
3.3	Basic Commissioning .....	34
3.4	Advanced Commissioning .....	40
<b>4</b>	<b>Using the SINAMICS G110 .....</b>	<b>53</b>
4.1	Frequency Setpoint (P1000) .....	53
4.2	Command Sources (P0700) .....	54
4.3	Types of Control using the Terminals .....	55
4.4	OFF and Braking Functions .....	61
4.5	Control Modes (P1300) .....	62
4.6	Faults and Alarms .....	62
<b>5</b>	<b>System Parameters .....</b>	<b>63</b>
5.1	Introduction to SINAMICS G110 System Parameters .....	63
5.2	Parameter Overview .....	64
<b>6</b>	<b>Troubleshooting .....</b>	<b>65</b>
6.1	Troubleshooting with the Standard Inverter LED .....	65
6.2	Troubleshooting with the BOP .....	65
<b>7</b>	<b>SINAMICS G110 Specifications .....</b>	<b>67</b>
<b>8</b>	<b>Options .....</b>	<b>71</b>

---

<b>9</b>	<b>Electro-Magnetic Compatibility (EMC)</b> .....	<b>73</b>
9.1	Electro-Magnetic Compatibility (EMC).....	73
<b>A</b>	<b>Removal of ‘Y’ Capacitor Link</b> .....	<b>79</b>
<b>B</b>	<b>DIN Rail Mounting Kit</b> .....	<b>80</b>
<b>C</b>	<b>Fitting the Basic Operator Panel</b> .....	<b>82</b>
<b>D</b>	<b>Description of the BOP</b> .....	<b>83</b>
<b>E</b>	<b>Applicable Standards</b> .....	<b>84</b>
<b>F</b>	<b>List of Abbreviations</b> .....	<b>85</b>
<b>Index</b>	.....	<b>87</b>

## List of Illustrations

Figure 2-1	Reforming Capacitors After a Period of Storage .....	19
Figure 2-2	Derating for Altitude .....	20
Figure 2-3	Dimensions of the SINAMICS G110 .....	23
Figure 2-4	Clearance distances for mounting the inverter .....	24
Figure 2-5	SINAMICS G110 Connection Terminals .....	27
Figure 2-6	SINAMICS G110 DC Terminals Connections .....	27
Figure 2-7	Motor and Power Connections .....	29
Figure 2-8	Wiring Guidelines to Minimize the Effects of EMI .....	30
Figure 2-9	SINAMICS G110 Flat Plate Variant .....	31
Figure 3-1	Inverter block diagram .....	34
Figure 3-2	Motor Base Frequency DIP Switch and Bus Termination .....	36
Figure 3-3	Basic operation – Analog and USS Variants .....	37
Figure 3-4	BOP .....	39
Figure 3-5	Changing parameters via the BOP .....	40
Figure 3-6	Typical Motor Rating Plate Example .....	48
Figure 3-7	Motor Overload PTC Connection .....	51
Figure 3-8	Typical Configurations of the Digital Output .....	52
Figure 4-1	Siemens standard control using ON/OFF1 and REV .....	58
Figure 4-2	Siemens standard control using ON/OFF1 and ON_REV/OFF1 .....	59
Figure 4-3	2-wire control using ON_FWD and ON_REV .....	60
Figure 4-4	3-wire control using FWDP, REVP and STOP .....	61
Figure 4-5	3-wire control using ON_PULSE, OFF1/HOLD and REV .....	62
Figure 5-1	Parameter Overview .....	66

## List of Tables

Table 2-1	Dimensions of the SINAMICS G110 Inverter .....	20
Table 2-2	Mounting Tightening Torques of SINAMICS G110 .....	22
Table 2-3	Flat Plate Power Losses and Thermal Specifications* .....	30
Table 3-1	Factory settings for operation using the standard inverter (Analog Variant) .....	35
Table 3-2	Factory settings for operation using the standard inverter (USS Variant) .....	36
Table 3-3	Modes of Operation Overview .....	41
Table 3-4	Commissioning Overview .....	44
Table 4-1	Redefined Digital Inputs .....	55
Table 7-1	SINAMICS G110 Performance Ratings .....	67
Table 7-2	Control Terminals Screwless Type – Wire Sizes .....	68
Table 7-3	Tightening Torques – Power Terminals .....	68
Table 7-4	SINAMICS G110 Specifications, Frame Size A .....	68
Table 7-5	Frame Sizes B and C .....	69
Table 7-6	Power losses SINAMICS G110 (230 V) inverters .....	69
Table 7-7	Harmonic currents Single Phase 230 V .....	70
Table 7-8	Derating with Pulse Frequencies .....	70
Table 9-1	Harmonic currents .....	74
Table 9-2	Case 1 - General Industrial .....	75
Table 9-3	Case 2 - Filtered Industrial .....	75
Table 9-4	Case 3 - Filtered for Residential, Commercial and Light Industry .....	76
Table 9-5	Compliance Table .....	77



# 1 Overview

## 1.1 The SINAMICS G110

The SINAMICS G110s are a range of frequency inverters for controlling the speed of three phase AC motors, incorporating the CPM 110 controlled power module. The various models available range from 120 W to 3.0 kW single-phase input.

The inverters are microprocessor-controlled and use state-of-the-art Insulated Gate Bipolar Transistor (IGBT) technology. This makes them reliable and versatile. A special pulse-width modulation method with selectable pulse frequency permits quiet motor operation. Comprehensive protective functions provide excellent inverter and motor protection.

The SINAMICS G110 CPM110 with its default factory settings is ideal for a large range of simple V/f motor control applications. Using the comprehensive range of programmable parameters provided with the inverter, the unit can be adapted for a wide range of applications. Parameters can be changed using either USS communications or the Basic Operator Panel (BOP).

The SINAMICS G110 is available in two variants; the Analog controlled variant and the USS controlled variant utilizing RS485 protocol. They are available as filtered and unfiltered inverters including a "Flat Plate" version which completes the range. They can be used in both 'stand-alone' applications as well as being integrated into 'Automation Systems'.

## 1.2 Features

### Main Characteristics

- Easy installation
- Easy commission
  - ◆ Quick commissioning
  - ◆ Reset function (allowing the reset of all values to the preset factory defaults)
- Rugged EMC design
- Can be operated on IT line supplies (unfiltered variants)
- 1 digital output – Isolated optocoupler
- 3 digital inputs (non-isolated)
- 1 Analog input, AIN: 0 – 10 V (Analog variant only). Can be used as 4<sup>th</sup> digital input
- High pulse frequencies for low-noise motor operation
- Status information and alarm messages using the Basic Operator Panel
- Optional Basic Operator Panel with the capability to clone parameter sets
- USS communications interface (USS variant only)
- PC to RS232 Connection Kit available

**Performance Characteristics**

- Fast repeatable response time to control signals
- Fast Current Limitation (FCL) for trip-free operation
- Built-in DC injection brake
- Compound braking
- Fixed Frequencies
- Motor potentiometer function
- Acceleration/deceleration times with programmable smoothing
- Multi-point V/f characteristic
- 150% overload for 60 seconds
- 2-wire/3-wire control
- Automatic restart after a mains failure
- Flying start

**Protection Characteristics**

- Overvoltage/undervoltage protection
- Overtemperature protection for the inverter
- Ground fault protection
- Short-circuit protection
- I<sup>2</sup>t thermal motor protection
- Motor stall prevention



## 2 Installation



### WARNINGS

- Work on the device/system by unqualified personnel or failure to comply with warnings can result in severe personal injury or serious damage to material. Only suitably qualified personnel trained in the setup, installation, commissioning and operation of the product should carry out work on the device/system.
- Only permanently-wired input power connections are allowed. This equipment must be grounded (IEC 536 Class 1, NEC and other applicable standards).
- If a Residual Current-operated protective Device (RCD) is to be used, it must be an RCD type B. However, if the SINAMICS G110 inverter is connected to a single-phase grounded-neutral star mains network, an RCD of type A is permissible.
- The mains input, DC and motor terminals, can carry dangerous voltages even if the inverter is inoperative; wait **5 minutes** to allow the unit to discharge after switching off before carrying out any installation work.
- This equipment must not be used as an 'emergency stop mechanism' (see EN 60204, 9.2.5.4)
- The minimum size of the earth-bonding conductor must be equal to or greater than the cross-section of the power supply cables.
- Safety regulations **must** not be compromised when installing inverters!

### CAUTION

The connection of power, motor and control cables to the inverter must be carried out as shown in Figure 2-8 on page 28, to prevent inductive and capacitive interference from affecting the correct functioning of the inverter.

## 2.1 General

### Installation after a Period of Storage

Following a prolonged period of storage, you must reform the capacitors in the inverter. **It is important that the time of storage is calculated from the time of manufacture and not the time of delivery.** The requirements are shown below.

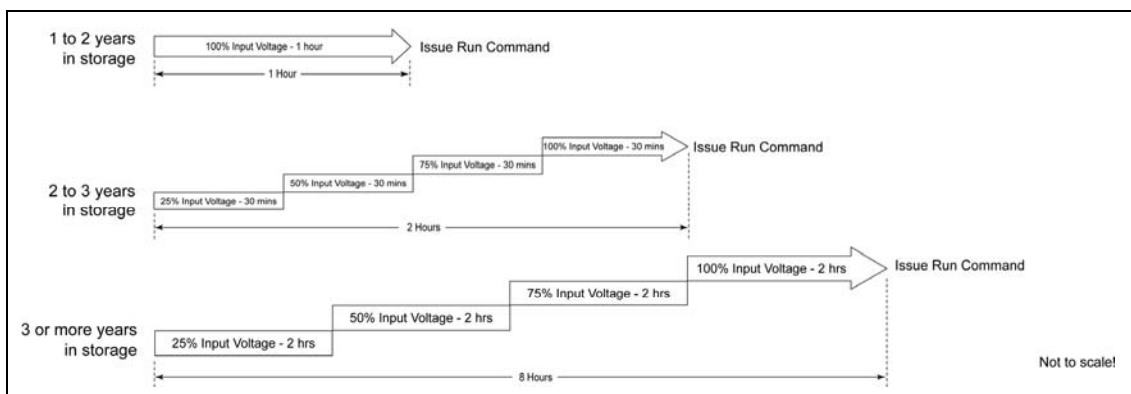

Figure 2-1 Reforming Capacitors After a Period of Storage

The serial numbers consist 13 characters and contains the date of manufacture, e.g. XAP214-123456

- XAP214-123456 Characters 1-2 are the site where the product is built
- XAP214-123456 Character 3 denotes the year e.g. R = 2003
- XAP214-123456 Character 4 is the month (1-9 =Jan-Sep, O =Oct, N =Nov, D =Dec)
- XAP214-123456 Characters 5-6 are the day of the month
- XAP214-123456 Character 7 is a separator
- XAP214-123456 Characters 8-13 are the sequential serial number 1-999999

## 2.2 Power Losses

For information on the typical power losses for the SINAMICS G110 inverter, please consult Table 7-6 on page 69.

## 2.3 Ambient operating conditions

### Temperature

-10°C to +50°C (14°F to 122°F) see Table 7-8 on page 70 for derating information.

### Humidity Range

≤ 95% Non-condensing

### Altitude

If the inverter is to be installed at an altitude greater than 1000m, derating will be required. Figure 2-2 below shows the permissible rated input voltages and output current for inverter installations from 1000 m to 4000 m above sea level.

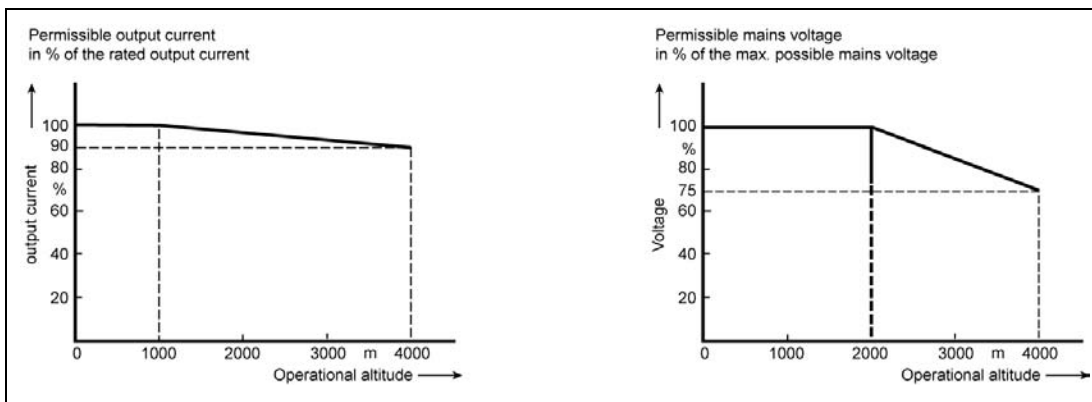

Figure 2-2 Derating for Altitude

### Shock and Vibration

Do not drop the inverter or expose to sudden shock. Do not install the inverter in an area where it is likely to be exposed to constant vibration.

Mechanical strength to EN 60721-3-3

- Deflection: 0.075 mm (10 ... 58 Hz)
- Acceleration: 10 m/s<sup>2</sup> (58 ... 200 Hz)

### Electromagnetic Radiation

Do not install the inverter near sources of electromagnetic radiation.

### Atmospheric Pollution

Do not install the inverter in an environment, which contains atmospheric pollutants such as dust, corrosive gases, etc.

### Water

Take care to site the inverter away from potential water hazards, e.g. do not install the inverter beneath pipes that are subject to condensation. Do not install the inverter where excessive humidity and condensation may occur.

### Installation and overheating



---

**WARNING**

The inverter **MUST** be front mounted in a vertical position to ensure optimum cooling.

---

Ensure that the inverter's air vents are not obstructed. For the recommended clearance distances see Figure 2-4 on page 22.

## 2.4 Harmonic Currents

For details of the harmonic currents with relation to the SINAMICS G110 inverter, please see Table 9-1 on page 74.

## 2.5 Derating with Pulse Frequencies

For details of derating with pulse frequencies with relation to the SINAMICS G110 inverter, please refer to Table 7-8 on page 70.

## 2.6 Overvoltage and Trip Levels

The inverter will protect itself from overvoltage and undervoltage. Internal overvoltage can occur during braking where internal voltages are forced high by energy from an external load.



---

**WARNING**

Although the inverter is designed to protect itself from overvoltage (if correctly commissioned); connecting the inverter to a voltage supply that is excessively high could result permanent damage to the inverter and seriously injure the user.

---

## 2.7 Overcurrent Trip Levels

The inverter will protect itself from short circuits between motor phases and from the motor phases to earth. The inverter will also protect itself against motor overload conditions which can produce excess currents.

## 2.8 Mechanical Installation



### WARNING

- To ensure the safe operation of the equipment, it must be installed and commissioned by qualified personnel in full compliance with the warnings laid down in these operating instructions.
- Take particular note of the general and regional installation and safety regulations regarding work on dangerous voltage installations (e.g. EN 50178), as well as the relevant regulations regarding the correct use of tools and personal protective equipment (PPE).
- Never use high voltage insulation test equipment on cables connected to the inverter.
- The mains input, DC and motor terminals, can carry dangerous voltages even if the inverter is inoperative; wait 5 minutes to allow the unit to discharge after switching off before carrying out any installation work.



### CAUTION

The control, power supply and motor leads **must** be laid separately. Do not feed them through the same cable conduit/trunking.

Table 2-1 Dimensions of the SINAMICS G110 Inverter

Frame Size	Output	Overall Dimensions			Depth with BOP fitted mm (inches)	Drilling Dimensions	
		H mm (inches)	W mm (inches)	D mm (inches)		H1 mm (inches)	W2 mm (inches)
A	120 W	150 (5.91)	90 (3.54)	116 (4.57)	124 (4.88)	140 (5.51)	79 (3.11)
A	250 W	150 (5.91)	90 (3.54)	116 (4.57)	124 (4.88)	140 (5.51)	79 (3.11)
A	370 W	150 (5.91)	90 (3.54)	116 (4.57)	124 (4.88)	140 (5.51)	79 (3.11)
A	550 W	150 (5.91)	90 (3.54)	131 (5.16)	139 (5.47)	140 (5.51)	79 (3.11)
A	750 W	150 (5.91)	90 (3.54)	131 (5.16)	139 (5.47)	140 (5.51)	79 (3.11)
A (Flat Plate)	120 W – 750 W	150 (5.91)	90 (3.54)	101 (4.01)	109 (4.29)	140 (5.51)	79 (3.11)
B	1.1 kW	160 (6.30)	140 (5.51)	142 (5.59)	150 (5.90)	135 (5.31)	127 (5.0)
B	1.5 kW	160 (6.30)	140 (5.51)	142 (5.59)	150 (5.90)	135 (5.31)	127 (5.0)
C	2.2 kW	181 (7.13)	184 (7.24)	152 (5.98)	160 (6.29)	140 (5.51)	170 (6.70)
C	3.0 kW	181 (7.13)	184 (7.24)	152 (5.98)	160 (6.29)	140 (5.51)	170 (6.70)

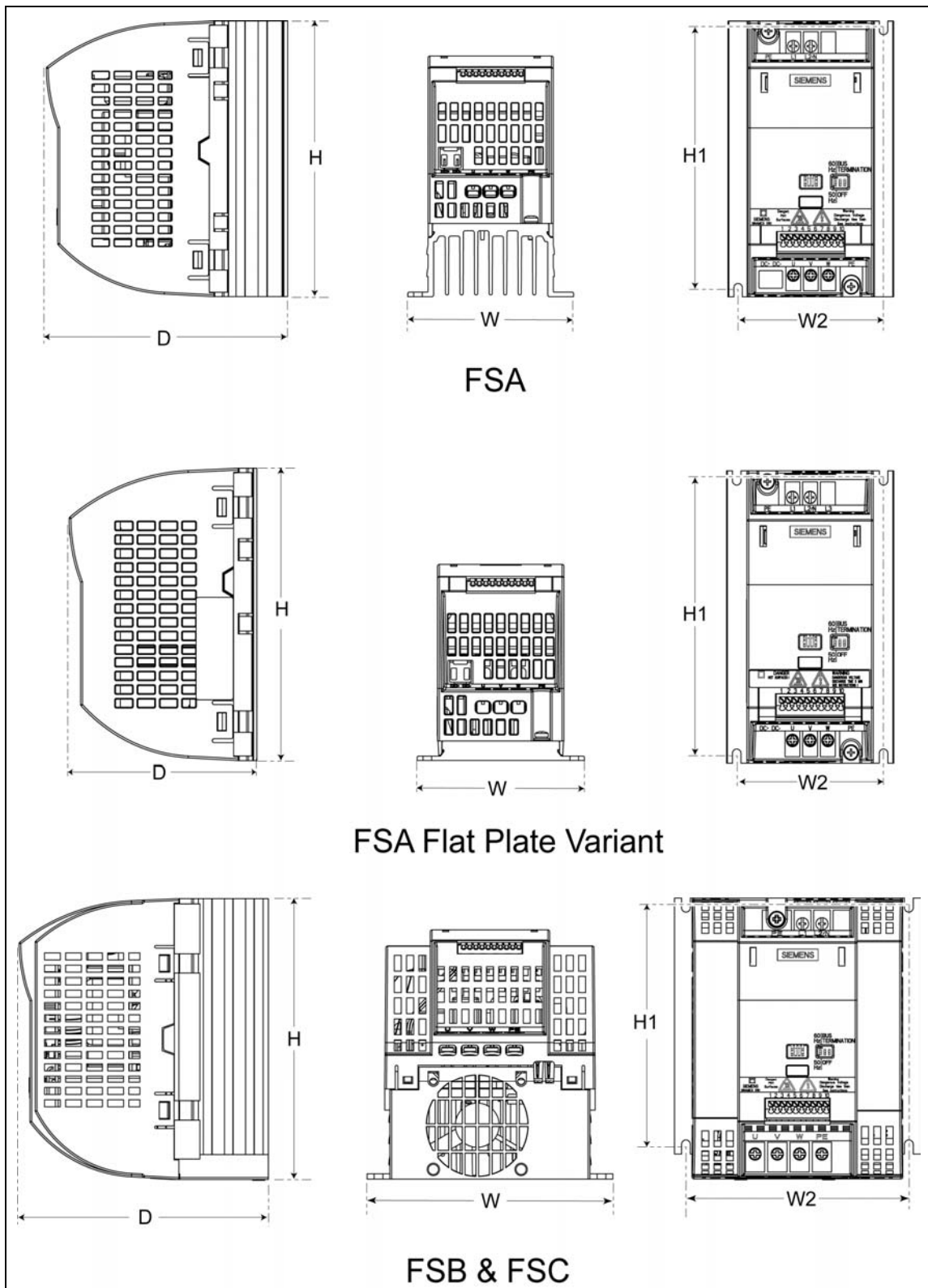

Figure 2-3 Dimensions of the SINAMICS G110

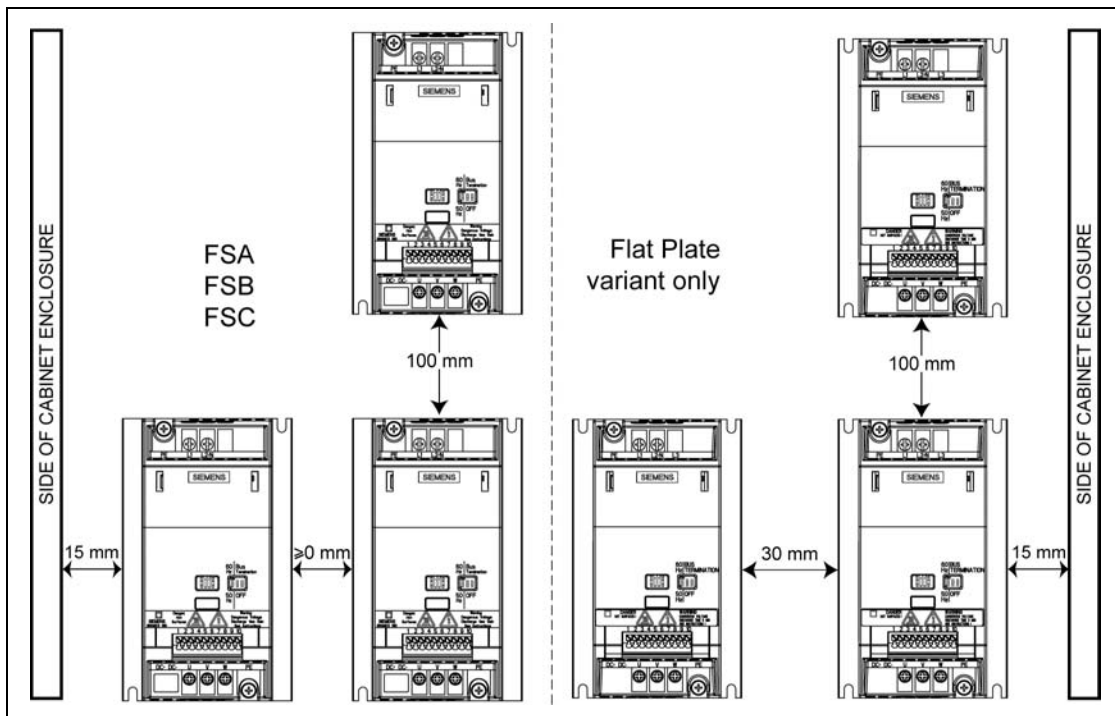

Figure 2-4 Clearance distances for mounting the inverter

Table 2-2 Mounting Tightening Torques of SINAMICS G110

Frame Size	Fixing Bolt (not supplied)		Tightening Torque of fixings
	Size	Qty	
A	M4	2	2.5 Nm (22.12 lbf.in) with washers fitted
B	M4	4	
C	M5	4	4.0 Nm (35.40 lbf.in) with washers fitted

## 2.9 Electrical Installation



### WARNING

- To ensure the safe operation of the equipment, it must be installed and commissioned by qualified personnel in full compliance with the warnings laid down in these operating instructions.
- Never use high voltage insulation test equipment on cables connected to the inverter.
- Take particular note of the general and regional installation and safety regulations regarding work on dangerous voltage installations (e.g. EN 50178), as well as the relevant regulations regarding the correct use of tools and personal protective gear.
- The mains input, DC and motor terminals, can carry dangerous voltages even if the inverter is inoperative; wait 5 minutes to allow the unit to discharge after switching off before carrying out any installation work.
- The inverters can be installed in a side-by-side configuration with a minimum distance as shown in Figure 2-4 on page 22.



### CAUTION

The control, power supply and motor leads **must** be laid separately. Do not feed them through the same cable conduit/trunking.

### 2.9.1 General

#### WARNING

**The inverter must always be grounded.** If the inverter is not grounded correctly, extremely dangerous conditions may arise within the inverter, which could prove potentially fatal. This also applies to ungrounded IT supplies

#### Operation with ungrounded (IT) supplies

- Filtered inverters **CANNOT** be used on ungrounded supplies.
- FSA unfiltered inverter can be used on ungrounded supplies.  
If an output phase is shorted to ground, the inverter may trip with F0001 (overcurrent).
- FSB and FSC can be used on ungrounded supplies, but it is necessary to cut the 'Y' capacitor link as described in Removal of 'Y' Capacitor Link on page 79.  
If an output phase is shorted to ground, the inverter may trip with F0001 (overcurrent).

### Operation with Residual Current Device

If an RCD (also referred to as ELCB or RCCB) is fitted, the SINAMICS G110 inverters will operate without nuisance tripping, provided that:

- A type B RCD is used.
- If the SINAMICS G110 inverter is connected to a single-phase grounded-neutral star mains network, an RCD of type A is permissible.
- The trip limit of the RCD is 30 mA.
- The neutral of the supply is grounded.
- Only one inverter is supplied from each RCD.
- The output cables are less than 25 m [82.02 ft](screened) or 50 m [164.04 ft] (unscreened).

### Operation with long cables



#### WARNING

Never use high voltage insulation test equipment on cables connected to the inverter.



#### CAUTION

The control, power supply and motor leads **must** be laid separately. Do not feed them through the same cable conduit/trunking.

All inverters will operate at full specification with the following cable lengths:

- ◆ 25 m (82.02 ft) [FSA filtered 10 m (32.81 ft)] screened cable
- ◆ 50 m (164.04 ft) unscreened cable

### 2.9.2 Power and motor connections



#### WARNING

- Isolate the mains electrical supply before making or changing connections to the unit.
- Ensure that the inverter is connected to the correct supply voltage: single-phase 230 V SINAMICS G110 inverters must not be connected to a higher voltage supply.

#### NOTES

- Ensure that the appropriate circuit-breakers/fuses with the specified current rating are connected between the power supply and inverter (see Technical Specifications on page 67).
- Use Class 1 75°C copper wire with the cross-sections as specified in Table 7-4 and Table 7-5 on pages 68 and 69 respectively (16 AWG minimum for UL compliance). For tightening torque see Table 7-2 on page 68.
- To tighten up the power terminal screws use a 4 - 5 mm cross-tip screwdriver.
- To conform to UL requirements the control terminals of the G110 inverter are UL Recognized for use only with solid conductors.
- To conform to UL requirements a UL listed Crimp Ring Terminal should be used on the following PE (ground) terminals of the G110 inverter: FSA – both input and motor PE terminals. FSB and FSC – the input PE terminal only.



**Access to the power and motor terminals**

Figure 2-5 below show the layout of the SINAMICS G110 inverter's control, power and motor connection terminals.

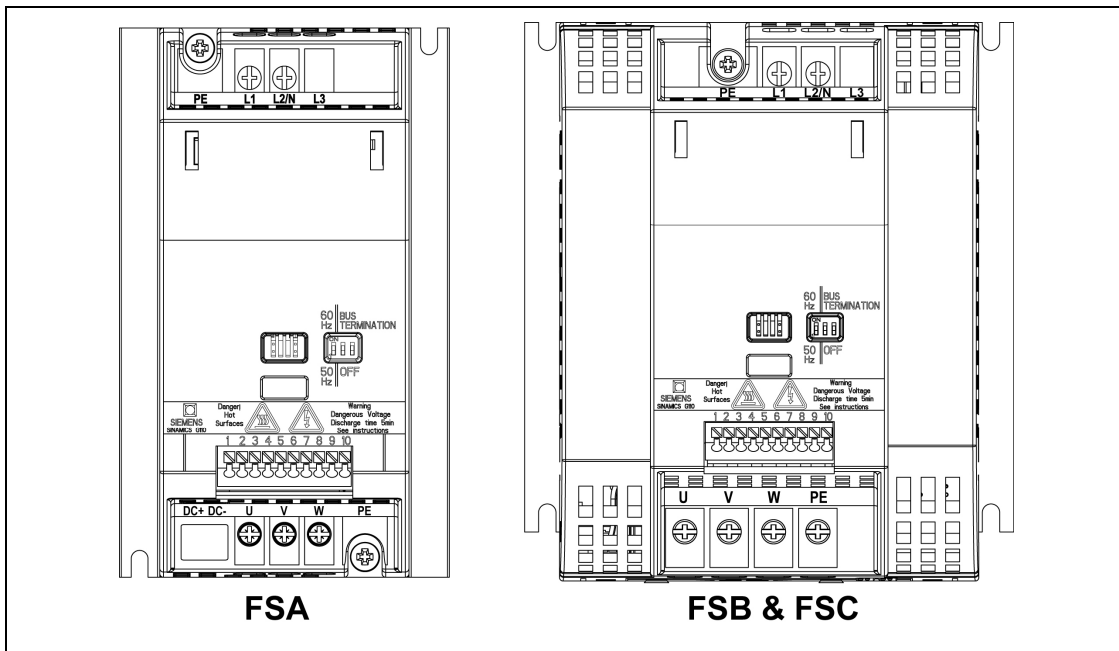

Figure 2-5 SINAMICS G110 Connection Terminals

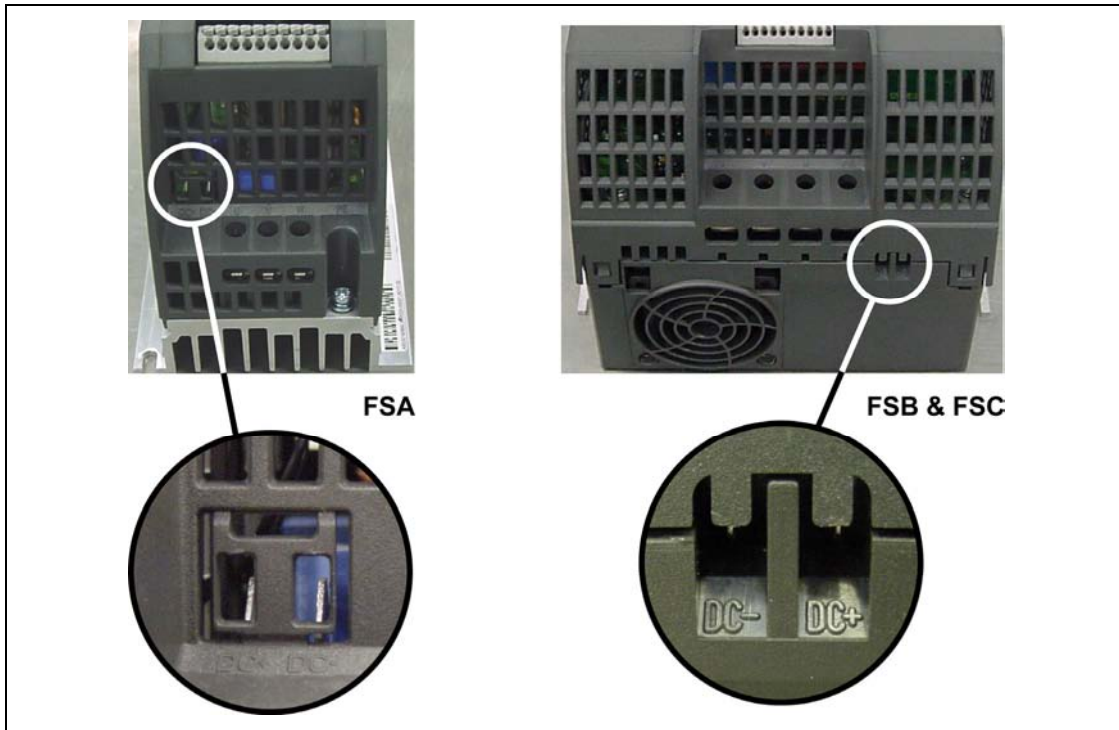

Figure 2-6 SINAMICS G110 DC Terminals Connections

On FSA to access the DC+/DC- terminals the cutout cover must be removed using a small pair of cutters, ensuring that no plastics from the cutout fall into the inverter housing (see Figure 2-6 on page 25). The terminal connection consists of two spades measuring 6.3 mm by 0.8 mm. With the cutout cover removed and no connections fitted to the spades, the inverter has only IP00 protection.

On FSB and FSC the DC+/DC- terminals are located on the underside at the bottom of the unit (see Figure 2-6 on page 25). To access the DC terminals the two upper plastic protectors (rabbits-teeth) must be removed by cutting them with a small pair of cutters, ensure that no plastics from the protectors fall into the inverter housing.

Connection of the DC bus between inverters is only envisaged for very basic applications. For example, a simple winder/unwinding machine where both inverters are powered from the same power supply and the same phase.

---

**Caution**

1. The DC+ terminal must be connected to the DC+ terminal of the other inverter and conversely the DC- terminal must be connected to the DC- terminal of the other inverter. Failure to connect the terminals correctly can result in severe damage to both inverters.
  2. Both inverters must be powered from the same power supply and the same phase.
  3. In the case of a short circuit on one of the inverters both inverters may be damaged.
  4. The inverters should be mounted as close as possible to reduce the length of the DC link cables.
- 

The following guidelines will keep the conformity of the inverter to UL requirements. If connections to the DC Link terminals are required, then the following (or equivalent) terminal crimps are recommended for use:

- ◆ Frame Size A – Molex crimp 19003-0001, Molex hand tool 19285-0036
- ◆ Frame Size B – Molex crimp 19017-0037, Molex hand tool 19285-0037 or 64001-0200.
- ◆ Frame Size C – Molex crimp 19017-0037, Molex hand tool 19285-0020 or 64001-0200.

The correct crimping tool must be used to join the crimp to the cable to ensure a correct and secure connection.

The specified crimps and tools are readily available from any large supplier of electrical connections. These can also be sourced by searching the Internet using the part number specified.

The following minimum cross-section for cables should be used when utilizing the DC terminals:

- ◆ FSA – 0.5 mm<sup>2</sup> (20 AWG)
- ◆ FSB – 1.5 mm<sup>2</sup> (16 AWG)
- ◆ FSC – 2.5 mm<sup>2</sup> (12 AWG)

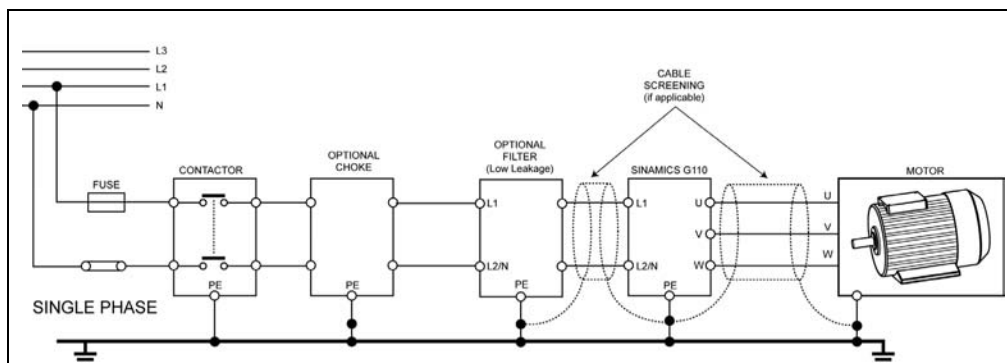

Figure 2-7 Motor and Power Connections

### 2.9.3 Avoiding Electro-Magnetic Interference (EMI)

The inverters are designed to operate in an industrial environment where a high level of EMI can be expected. Usually, good installation practices will ensure safe and trouble-free operation. If you encounter problems, follow the guidelines stated below.

#### Action to Take

- Ensure that there is a good metal-to-metal connection between the inverter and its (grounded) metal mounting surface.
- Ensure that all equipment in the cubicle is well grounded using short, thick grounding cable connected to a common star point or busbar
- Make sure that any control equipment (such as a PLC) connected to the inverter is connected to the same ground or star point as the inverter via a short thick link.
- Connect the return ground from the motors controlled by the inverters directly to the ground connection (PE) on the associated inverter
- Flat grounding conductors are preferred as they have lower impedance at higher frequencies
- Terminate the ends of the cable neatly, ensuring that unscreened wires are as short as possible
- Separate the control cables from the power cables as much as possible, using separate trunking, cross them if necessary at 90° to each other.
- Whenever possible, use screened leads for the connections to the control circuitry
- Ensure that the contactors in the cubicle are suppressed, either with R-C suppressors for AC contactors or 'flywheel' diodes for DC contactors fitted to the coils. Varistor suppressors are also effective.
- Use screened or armored cables for the motor connections and ground the screen at both ends using the cable clamps
- For EMC compliant installation using the DIN Rail Mounting Kit, please refer to Appendix B on page 80.

The inverter can be screened using the methodology shown in Figure 2-8 below.

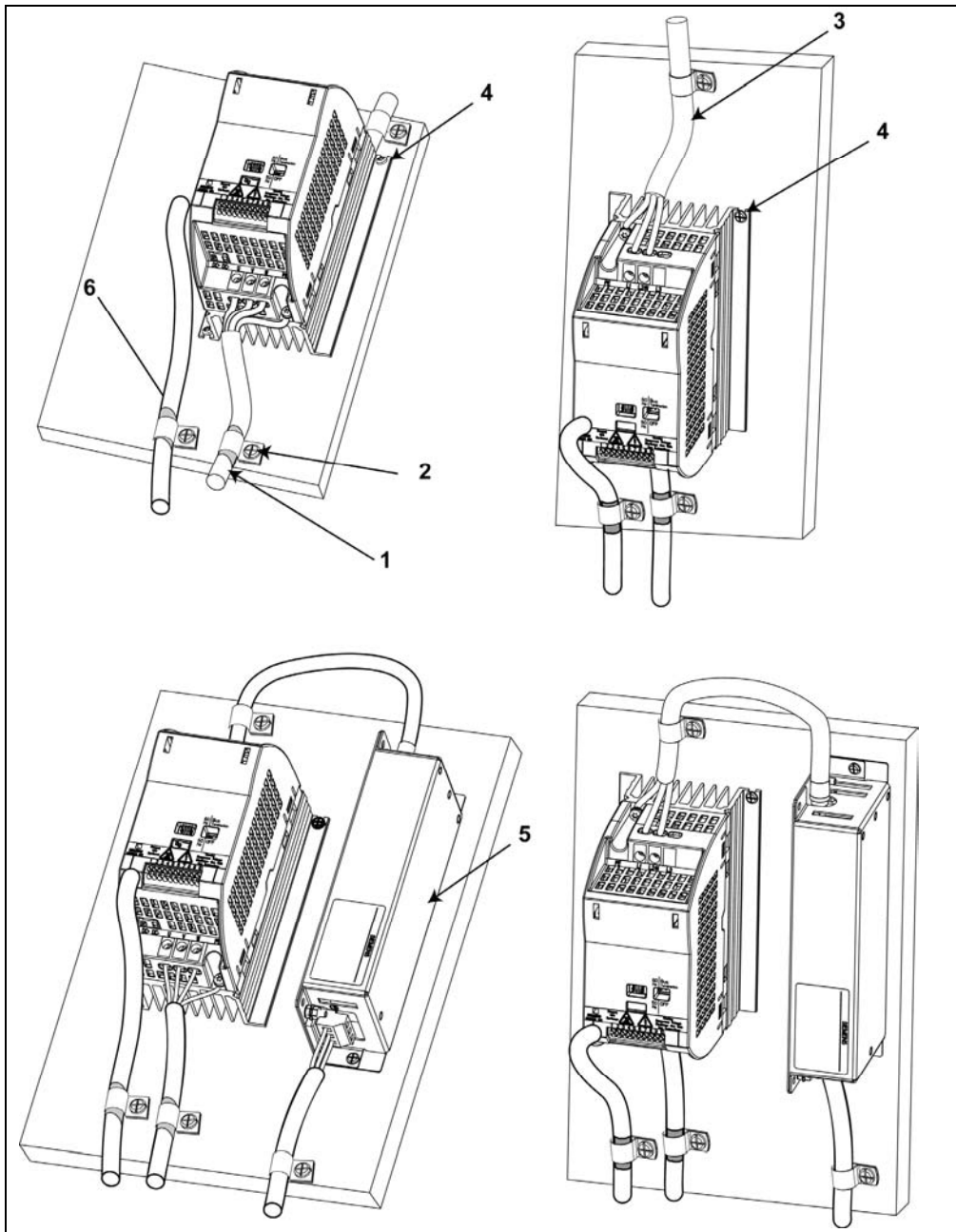

Figure 2-8 Wiring Guidelines to Minimize the Effects of EMI

**Legend**

- 1 Motor cable
- 2 Use suitable clips to fix motor and control cable screens securely to metal back plate
- 3 Mains power cable
- 4 Retaining screw (inverter fixing bolts)
- 5 Line commutating Choke
- 6 Control cable

## 2.10 SINAMICS G110 Flat Plate Variant

The SINAMICS G110 Flat Plate variant has been designed to allow greater flexibility in the installation of the inverter by an advanced user as an individual unit or as part of an automation system. Adequate measures must be taken to ensure the correct heat dissipation, which may require an additional external heatsink outside the electrical cabinet enclosure (see Table 2-3 on page 30).

The installation procedures, both mechanical and electrical, starting on page 17 of these Operating Instructions should be performed unless otherwise stated below. Ensuring that all warnings and cautions given throughout the procedures are strictly observed.



Figure 2-9 SINAMICS G110 Flat Plate Variant



### WARNING

Operation with the input voltages less than 230 V and 50 Hz or with a pulse frequency greater than 8 kHz will cause an additional heat load on the inverter. These factors must be taken into account when designing the installation conditions and must be verified by a practical load test.

### Cooling Considerations

1. For the correct dimensioning of the panel, please consult the panel builder and his technical documentation.
2. For the correct dimensioning of the external heatsink, please refer to the technical data as shown in Table 2-1 on page 20.
3. The rear plate must be able to withstand at least 95°C during fault free operation and carry the heat load (steel or aluminium plate) under the full load conditions and the maximum operating temperatures [-10°C to +50°C (14°F to 122 °F)]. For further information see Table 2-3 on page 30.
4. The minimum clearance distances of 30 mm at both sides and 100 mm vertical spacing at both sides must be observed.
5. It is recommended that the mounting area of the rear plate has to be, as a minimum, at least the same area of the flat plate on the inverter.
6. Side by side or stacked mounting is not allowed for the SINAMICS G110 Flat Plate inverter.

### Installation

1. Prepare the mounting surface for the inverter using the dimensions given in Table 2-1 on page 20.
2. Ensure that any rough edges are removed from the drilled holes.
3. Ensure the inverter's Flat Plate is clean and free from dust and grease.
4. The mounting surface for the Flat Plate and if applicable the external heatsink must be:
  - ◆ Clean and free from dust and grease.
  - ◆ Smooth.

- ◆ Free from dents and holes.
  - ◆ Made of metal (steel or aluminium).
  - ◆ Must not be painted.
  - ◆ Must be free from rust.
5. Apply coating of heatsink/thermal contact paste to the inverter's flat plate.
  6. Ensure that the contact paste is spread evenly over the rear surface of the Flat Plate.
  7. Mount the inverter using four M4 screws.
  8. Ensure that the inverter is mounted securely and the M4 screws are tightened to the correct torque of 2.5 Nm (22.12 lbf.in).
  9. If required, connect the external heatsink on the other side of the rear plate, ensuring an evenly spread thermal contact paste is apply.
  10. When the installation is completed the effectiveness of the cooling should be verified by a load test.
  11. Check that there is no trip F0004.

Table 2-3 Flat Plate Power Losses and Thermal Specifications\*

	120 W	250 W	370 W	550 W	750 W
Operating temperature range (°C)	-10 to +50				-10 to +40
Total losses (W)	22	28	36	43	54
Lineside and control losses (W)	9	10	12	13	15
Recommended thermal resistance of heatsink (K/W)	3.0	2.2	1.6	1.2	1.2
Recommended output current (A)	0.9	1.7	2.3	3.2	3.9

\*The losses given in Table 2-3 are applicable for units fitted with 25 m of screened cable

### 3 Commissioning

This section describes the different methods of how to commission and run the SINAMICS G110 inverter. A prerequisite is that the mechanical and electrical installation has been completed as described in Section 2, starting on page 17 of these Operating Instructions.



---

#### WARNING

- SINAMICS G110 inverters operate at high voltages.
  - When operating electrical devices, it is impossible to avoid applying hazardous voltages to certain parts of the equipment.
  - Emergency Stop facilities according to EN 60204 IEC 204 (VDE 0113) must remain operative in all operating modes of the control equipment. Any disengagement of the Emergency Stop facility must not lead to uncontrolled or undefined restart.
  - Wherever faults occurring in the control equipment can lead to substantial material damage or even grievous bodily injury (i.e. potentially dangerous faults), additional external precautions must be taken or facilities provided to ensure or enforce safe operation, even when a fault occurs (e.g. independent limit switches, mechanical interlocks, etc.).
  - Certain parameter settings may cause the inverter to restart automatically after an input power failure.
  - Motor parameters must be accurately configured for motor overload protection to operate correctly above 5 Hz.
  - This equipment is capable of providing internal motor overload protection in accordance with UL508C. Refer to P0610 and P0335, I<sup>2</sup>t is ON by default.
  - This equipment is suitable for use in a circuit capable of delivering not more than 10,000 symmetrical amperes (rms), for a maximum voltage of 230 V, when protected by an H or K type fuse, a circuit breaker or self-protected combination motor controller.
  - This equipment must not be used as an 'emergency stop mechanism' (see EN 60204, 9.2.5.4)
- 

#### CAUTION

Only qualified personnel may enter settings in the control panels. Particular attention must be paid to safety precautions and warnings at all times.

---

#### NOTES

- The inverter does not have a main power switch and is live when the mains supply is connected. It waits, with the output disabled, until the RUN button is pressed or for the presence of a digital ON signal at terminal 3.
  - The inverter is designed to use control input signals to start and stop the motor.
-

### 3.1 Block Diagram

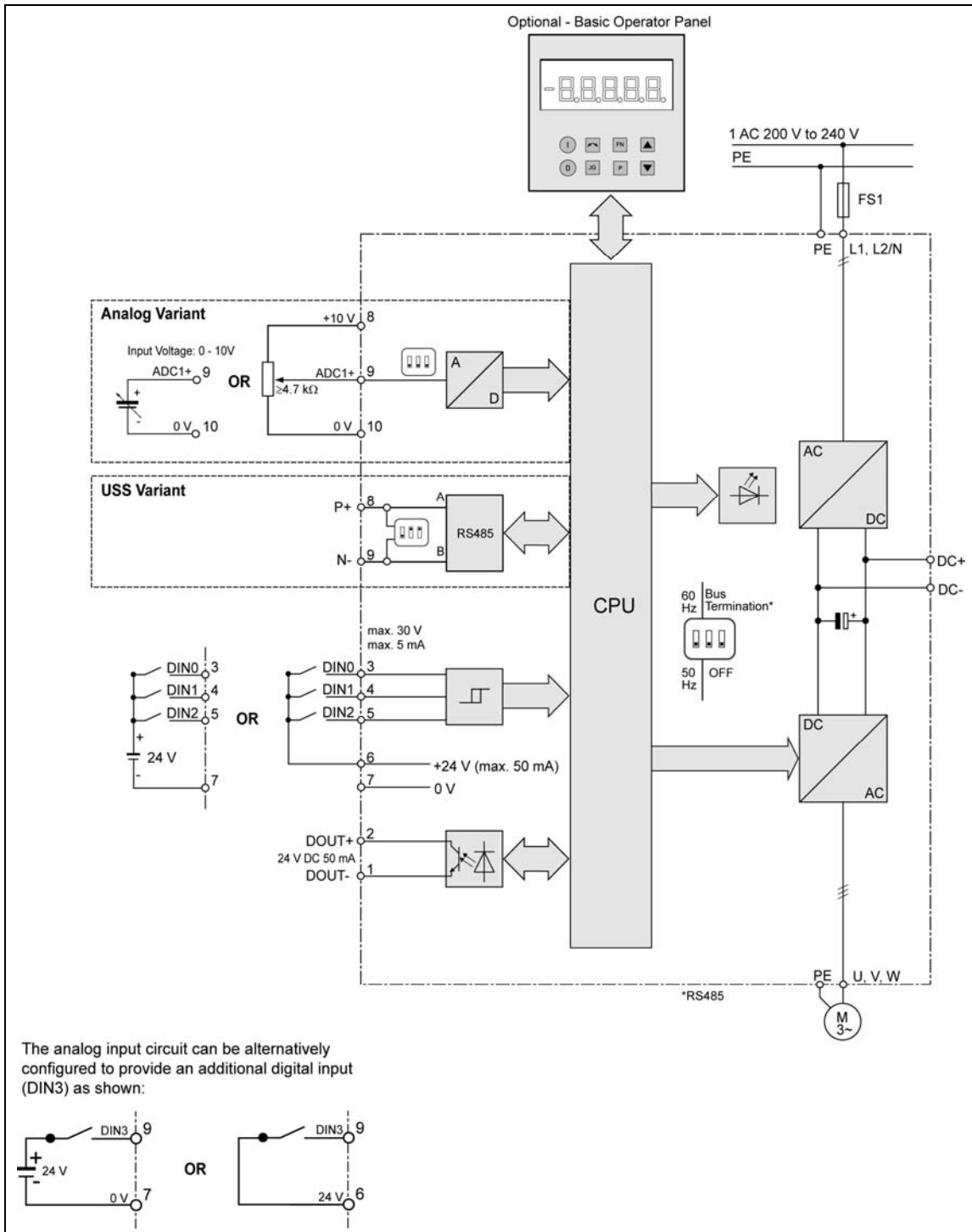

Figure 3-1 Inverter block diagram



## 3.2 Commission Modes

**Basic commissioning** of the SINAMICS G110 Inverter can be performed by using one of the following methods which are suitable for a large range of applications:

- Using the inverter with its factory default settings by connecting analogue and digital inputs **or** using the RS485 connections (see Section 3.3.1 on page 35).
- Using the optional Basic Operator Panel (BOP) (see Section 3.3.2. on page 37).

**Advanced commissioning** allows the user to suitably adapt the inverter to the specific application. Section 3.4 contains information about:

- Using a PLC to communicate with the inverter via the USS protocol (see Section 3.4.1 on page 42).
- Using the PC Tool "STARTER" which communicates with the inverter via USS protocol (see Section 3.4.1 on page 43).
- Optimal configuration of the inverter by setting parameters using 'Quick Commissioning' (see Section 3.4.4 on page 46).
- Resetting inverter parameters to factory default (see Section 3.4.5 on page 49).
- Connecting a PTC temperature sensor to the inverter (see Section 3.4.6 on page 49).
- Parameter Cloning with the BOP (see Section 3.4.7 on page 49).

---

### Notes

When utilizing USS communications, a common 0 V reference connection is required between all devices on the USS bus. Terminal 10 on the control board can be used for this purpose.

---

The SINAMICS G110 inverter is available as two variants:

1. **Analog Variant**  
The analog variant is suited to stand-alone applications. This variant is designed to be controlled using external switches and a potentiometer utilizing the analog input and digital inputs. Switches and potentiometers are not provided as standard with the inverter.
2. **USS Variant**  
The USS variant is suited to inverter networks. This variant is designed to be controlled utilizing the USS protocol via the RS485 communications interface. A number of inverters can then be connected and controlled via the same communications bus.

The variant can be identified by reading the MLFB from the rating label and comparing it to the MLFBs listed in Table 7-4 and Table 7-5 on pages 68 and 69 respectively.

Since the SINAMICS G110 is available in two variants; different options for the commissioning of the inverters are available to the user. These commissioning options are described in the following sections covering the 'Basic Commissioning' and 'Advanced Commissioning'.

### 3.3 Basic Commissioning

The SINAMICS G110 is supplied with default parameter settings to cover the following basic operation:

- The motor rating data; voltage, current and frequency data has already been keyed into the inverter to ensure that the motor is compatible with the inverter. (A Siemens standard motor is recommended).
- Linear V/f motor speed, controlled by an analogue potentiometer, or via the RS485 connection using the USS variant.
- Maximum speed  $3000 \text{ min}^{-1}$  corresponding to a 2-pole motor with 50 Hz ( $3600 \text{ min}^{-1}$  with 60 Hz); controllable using a potentiometer via the inverter's analogue input, or via the RS485 connection using the USS variant.
- Ramp-up time / Ramp-down time = 10 s.

#### Changing the motor base frequency

The default motor base frequency of the SINAMICS G110 inverter is 50 Hz. In some parts of the world motors are designed for a base frequency of 60 Hz. Changing the motor default base frequency is accomplished using the DIP switch which is provided on the front of the inverter to select the required base frequency.

A small screwdriver will be required to change the position of the DIP switches.

DIP switch 1 is used to change the motor base frequency of the inverter, by default it is in the position '50 Hz'. See Figure 3-2. In the default position (50 Hz) the output power will be displayed in kW (if a BOP is fitted to the inverter). In addition, all motor related parameters will be calculated using the 50 Hz setting.

To change the motor base frequency to 60 Hz, DIP switch 1 must be set to the position '60 Hz'.

The DIP switch must be set to the required frequency before power is applied to the inverter. On power up the inverter will read the DIP switch setting and calculate the following motor related parameters:

- Rated Motor Frequency (P0310)
- Maximum Motor Frequency (P1082)
- Reference Frequency (P2000)



Figure 3-2 Motor Base Frequency DIP Switch and Bus Termination

### 3.3.1 Factory Settings

The inverter has already been programmed at the factory for standard V/f applications on a Siemens standard four-pole 3-phase induction motor, that has the same power rating as the inverters.

Controlling the speed of the motor is accomplished by connecting the analog inputs on the analog variant (switches and the potentiometer are not supplied with the inverter) or via the RS485 connections on the USS variant as shown in Figure 3-3 below.

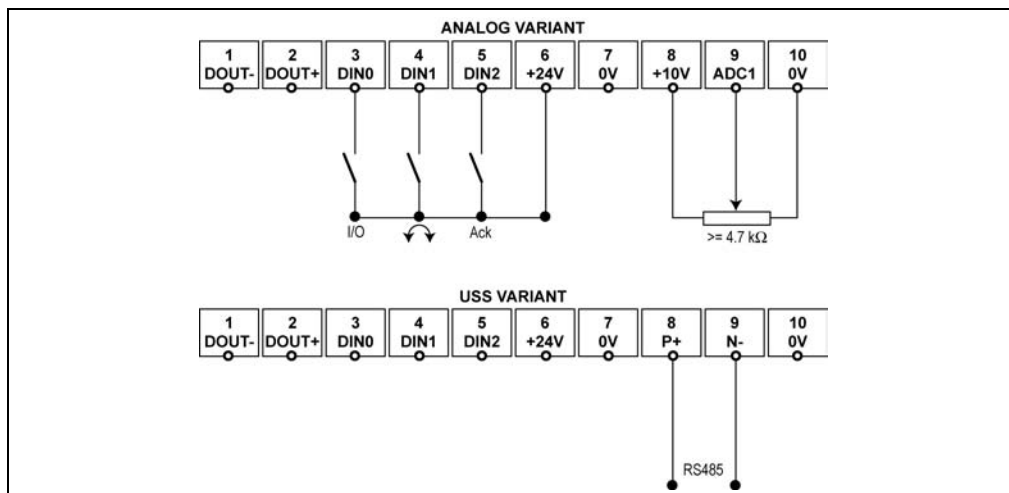

Figure 3-3 Basic operation – Analog and USS Variants

The inverter can be used with its default settings for a wide range of applications. The default settings are shown in Table 3-1 (Analog variant) and Table 3-2 (USS variant). The terminal layout is shown in Figure 3-3 above.

**Note**

The motor base frequency might have to be changed as described in the previous section on page 34.

Table 3-1 Factory settings for operation using the standard inverter (Analog Variant)

Description	Terminals	Parameter Default	Default Operation
Frequency Setpoint Source	9	P1000 = 2	Analog Input
Command Source	3,4 & 5	P0700 = 2	(see below)
Digital Input 0	3	P0701 = 1	ON/OFF1
Digital Input 1	4	P0702 = 12	Reverse
Digital Input 2	5	P0703 = 9	Fault Acknowledge
Control Method	-	P0727=0	Siemens Standard Control

With the default settings of the inverter (Analog variant) the following is possible:

- Start and stopping the motor (DIN0 via external switch)
- Reversing the motor (DIN1 via external switch)
- Fault Acknowledgement (DIN2 via external switch).

Controlling the speed of the motor is accomplished on the Analog variant by connecting a potentiometer ( $\geq 4.7 \text{ k}\Omega$ ) to the analog input (external switches and potentiometers are not supplied with the inverter) or via the RS485 connections on the USS variant as shown in the Figure 3-3 above.

Table 3-2 Factory settings for operation using the standard inverter (USS Variant)

Description	Terminals	Parameter Default	Default Operation
USS Address	8/9	P2011 = 0	USS Address = 0
USS Baud Rate	8/9	P2010 = 6	USS Baud Rate = 9600 bps
USS PZD Length	8/9	P2012 = 2	Two 16 bit words are in the PZD part of the USS telegram. (PZD = process data)
Frequency Setpoint	8/9	P1000 = 5	Frequency demand via USS protocol (HSW)
Command Source	8/9	P0700 = 5	Via USS protocol (STW)

Controlling the speed of the motor on the USS variant is accomplished by connecting the RS485 connections as shown in Figure 3-3 on page 35.

(USS master or software tool are not supplied with the inverter).

When controlling a USS variant inverter the process data is continually exchanged between the master and the slaves.

The PZD part of the USS telegram is used for the main setpoint and for controlling the inverter.

Depending on the direction of communications (PZD from USS Interface or PZD to USS Interface) PZD transmits either a control word (STW) and setpoint (HSW) or a status word (ZSW) and an actual value (HIW).

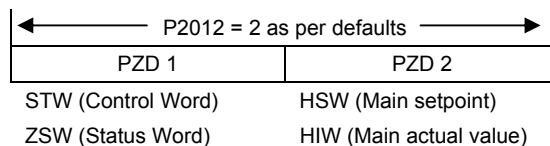

## Warnings and faults states on the inverter

The LED indicates the operating status of the inverter. The LED also indicate various warnings or fault states. In section 6.1 on page 65, the inverter states indicated by the LED are explained.

## Bus termination on USS variant

The USS variant of the SINAMICS G110 inverter uses RS485 protocols to communicate with the controlling system and all other inverters connected to the network.

It is necessary to terminate the last inverter on the network bus. This is achieved by setting the Bus Termination DIP switches on the front of the inverter to the 'Bus Termination' position (as shown in Figure 3-2 on page 34). It is important that both DIP switches (2 and 3) are set to the 'Bus Termination' position (not in the OFF position). A small screwdriver will be required to change the position of the DIP switches.

### 3.3.2 Commissioning with the Optional Basic Operator Panel

If the optional 'Basic Operator Panel' (BOP) is available, the control signals and speed reference can easily be set by pressing the relevant buttons. The BOP also provides easy access to the inverter parameters. This section describes how to commission and start the inverter with the minimum of effort, using the BOP.

For advanced use of the BOP to perform for example, the full inverter commissioning see Section 3.4.1 on page 42 or refer to Section 3.4.7 on page 49 for information about parameter cloning using the BOP.

For instructions on how to fit the BOP to the inverter, please refer to Appendix C on page 82 and for a description of the buttons see Appendix D on page 83.

- The BOP must be connected directly to the inverter and not remotely connected via a cable.
- The BOP can be fitted to and removed from the inverter whilst power is applied.
- The inverter will automatically recognize that the BOP has been fitted to the inverter and give the user access to the parameters. To run the inverter (start/stop, setpoint) using the BOP, parameters P0700 (command source, i.e. start/stop, reverse, jog) and P1000 (frequency setpoint) have to be set to 1. Alternatively, P0719 can be set to 11 which is described below.



Figure 3-4 BOP

---

#### Note

The motor base frequency might have to be changed as described in the previous section on page 34.

---

## Changing parameters with the Basic Operator Panel

The description below serves as an example that shows how to change any parameters using the BOP. These examples can also be used as a guide to configuring the inverter for running via the BOP (start/stop commands and the frequency setpoint are input on the BOP).

### Changing P0003 – parameter access level

Step	Result on display
1 Press <b>P</b> to access parameters	r0000
2 Press <b>▲</b> until P0003 is displayed	P0003
3 Press <b>P</b> to display the parameter value	1
4 Press <b>▲</b> or <b>▼</b> to set the required value (set to 3)	3
5 Press <b>P</b> to confirm and store the value	P0003
6 All level 1 to level 3 parameters are now visible to the user.	

### Changing P0719 an indexed parameter – setting BOP control

Step	Result on display
1 Press <b>P</b> to access parameters	r0000
2 Press <b>▲</b> until P0719 is displayed	P0719
3 Press <b>P</b> to access the parameter value	in000
4 Press <b>▲</b> or <b>▼</b> to select index 1	in001
5 Press <b>P</b> to display actual set value	0
6 Press <b>▲</b> or <b>▼</b> to the required value	11
7 Press <b>P</b> to confirm and store the value	P0719
8 Press <b>▼</b> until r0000 is displayed	r0000
9 Press <b>P</b> to return the display to the standard drive display (as defined by the customer)	

Figure 3-5 Changing parameters via the BOP

**NOTE**

In some cases - when changing parameter values - the display on the BOP shows **busy**. This means the inverter is busy with tasks of a higher priority.

**Changing single digits in parameter values**

For changing the parameter value rapidly, the single digits of the display can be changed by performing the following actions:

1. Ensure you are in the parameter value changing level (see section "Changing parameters with Basic Operator Panel" above).
2. Press **Fn** (function button), which causes the right hand digit to blink.
3. Change the value of this digit by pressing **▲** or **▼**.
4. Press **Fn** (function button) again causes the next digit to blink.
5. Perform steps 2 to 4 until the required value is displayed.
6. Press the **P** to leave the parameter value changing level.

**NOTE**

The function button **Fn** may also be used to acknowledge a fault condition.

**Commissioning of motorpoti (MOP) function**

Simple motor speed control can be achieved using the motorpoti (MOP) function of the optional BOP (for using the MOP see also P1031 and P1040 in the Parameter List).

The BOP motor control functions are disabled by default. To control the motor via the BOP, the following settings must be completed (see also "Changing parameters with the Basic Operator Panel" above):

- P0719 = 11 (enables start/stop button on the BOP and enables the motor potentiometer setpoint from the BOP).

Alternatively set:

- ◆ P0700 = 1 (enables the start/stop button on the BOP).
- ◆ P1000 = 1 (this enables the motor potentiometer setpoints).

1. Press the **I** button to start the motor.
2. Press the **▲** button while the motor is turning. Motor speed increases to 50 Hz.
3. When the inverter reaches 50 Hz, press button **▼**. Motor speed and displayed value are decreased.
4. Change the direction of rotation by pressing the **↻** button.
5. Stop the motor by pressing the **⏻** button.

If the BOP has been set as the command source (P0700 = 1 or P0719 = 10 - 15), the inverter will stop if the BOP is removed.

---

**Note**

The speed reading on the BOP is correct if a Siemens standard 4-pole 3-phase induction motor is connected. Otherwise the motor rated speed has to be changed (see Section 3.4.4 on page 46).

---

**Warning and fault status**

When the BOP is fitted, the fault number or warning number, which is in parameters r0947 or r2110, will be displayed should a fault or warning condition occur.

For further details, please refer to the Parameter List.

### 3.4 Advanced Commissioning

This section describes the advanced commissioning that allows the user to optimally configure the inverter to their specific motor and application. It also describes how to operate the SINAMICS G110 inverter in a specific mode.

The advanced commissioning requires the user to directly access the parameters held within the inverter utilizing either a USS master (for example, a PLC), the Basic Operator Panel (BOP), or the STARTER software as listed in Table 3-3 on page 41.

Additional equipment may be required to operate the inverter in some modes. As a consequence, several commissioning methods are offered to the user (see Table 3-4 on page 44).

#### 3.4.1 Modes of Operation

The SINAMICS G110 inverter can be connected and operated in a variety of modes. An overview is given in Table 3-3 on page 41. The modes are described in detail in the following sections.

---

**Note**

The SINAMICS G110 inverter can be connected in more than one mode at any time, for example, the BOP is attached, USS used and switches connected to terminals.

---



Table 3-3 Modes of Operation Overview

Mode	Analog variant	USS Variant	Legend (Required Optional Equipment)
TERMINAL	✓ (Requires switches and potentiometer)	✓ (Analogue input not supported, command source can however be via external switches)	<b>①</b> = BOP <b>②</b> = PC to Inverter Connection Kit <b>③</b> = STARTER software ✓ = supported
SERIAL (USS-RS485)	<b>Not supported</b>	✓	
SERIAL (USS-RS232)	✓ <b>②</b>	✓ <b>②</b> (USS-RS232 and USS-RS485 cannot be used simultaneously)	
BOP	✓ <b>①</b>	✓ <b>①</b>	
STARTER	✓ <b>② ③</b>	✓ ( <b>③</b> either with RS485 converter on terminals x8/x9 or with <b>②</b> )	

**Examples for Table 3-3:**

- The Analog variant can be operated in TERMINAL mode. This has been described earlier in Section 3.3.1. The USS variant can also be operated in TERMINAL mode. However, since no analog input is available, the frequency setpoint has to be provided from one of the other modes.
- The USS variant can be directly controlled using the SERIAL (USS-RS485) mode. This mode is not supported on the Analog variant.

**Note**

- Both variants will require **②** (PC to Inverter Connection Kit) if operated in mode SERIAL (USS-RS232).
- The hardware setup for SERIAL (USS-RS232) mode can also be used for STARTER mode which additionally requires **③** (STARTER software).

The SINAMICS G110 inverters can be operated using the following modes:

### Terminal

This mode provides a simple method of controlling the inverter using switches and a potentiometer and is only available on the Analog variant. The commissioning for this mode is described in Section 3.3.1 on page 35. No advanced commissioning is possible!

### Serial

The USS protocol can be used either via the RS232 or via the RS485 interface to commission, parameterize and run the inverter. The USS-RS485 interface is only available on the USS variant (see Section 3.3.1) and can be directly connected to an inverter network or a USS master such as a PLC. The USS-RS232 interface can be used with both variants but requires the optional 'PC to Inverter Connection Kit'.

The prerequisite for using the serial interfaces is that the baud rate and the bus address of the inverter must be established prior to any parameterization or commissioning.

For further details see the following parameters (details of the default settings given in Section 3.3.1.):

- P2010 – Baud rate
- P2011 – Bus address
- P2012 – PZD Length

The parameters can be changed by using the optional BOP. A change via the USS protocol is also possible, however, this requires the USS master to reconnect with the new settings.

The Parameter List provides information about further parameters and settings for the USS telegram.

The default values of P2010, P2011 and P2012 are shown in Table 3-2 on page 36.

Set P0719 = 55 or set the command source P0700 = 5 and the frequency setpoint P1000 = 5 for complete inverter control when in SERIAL mode.

### BOP

If the factory default settings of the inverter are not suitable for your application, the inverter can be modified for the required application using the optional Basic Operator Panel (BOP).

The BOP allows the user direct access to the parameters of the SINAMICS G110 inverter.

With the BOP attached to the inverter, the user can perform the following functions:

- Change parameter values
- Monitor specific parameters
- Clone parameters from one inverter to another inverter. This is of great value when dealing with multiple inverters as in the case of the USS variants (see Section 3.4.7 on page 49).

The BOP can be used to configure several SINAMICS G110 inverters. This is accomplished by using the BOP to set the required parameters and once the process is complete, then the BOP can be removed and used on another inverter.

The BOP contains a five-digit display that allows the user to read and change parameter values.

For a complete description of the buttons on the BOP and the procedure for attaching the BOP to the inverter, see Appendices C and D starting on page 82. For more information on using the BOP, please refer to Section 3.3.2 on page 37. If a BOP is fitted and the output frequency is selected to be displayed (P0005 = 21) the corresponding setpoint is displayed approximately every 1.0 seconds while the inverter is stopped. Set P0719 = 11 or set the command source P0700 = 1 and the frequency setpoint P1000 = 1 for complete inverter control when in BOP mode (see also P1031 and P1040).

## STARTER Software



---

### Warning

During the parameter download with the STARTER commissioning tool to the inverter, the digital output may produce a spurious signal.

Prior to performing a download to the inverter appropriate counter-measures **must** be taken to ensure that any suspended load is secured, for example, by the use of external brakes or the load being lowered to ground level and secured.

---

To assist in the quick and efficient changing of parameters and commissioning, the software tool STARTER can be used. This software is provided on the Documentation and PC Tool CD-ROM (orderable as a separate item) or it can be downloaded from the internet.

STARTER provides the user with a graphical interface that provides easy access to the inverter's parameters via a parameter database or a configuration wizard to guide the user through the correct set-up and configuration procedures.

The STARTER software runs on the following operating systems:

- Windows NT
- Windows 2000
- Windows XP Professional

The STARTER software is self-explanatory and is supported by means of an on-line help facility.

In order to use the STARTER software, the user will require the optional 'PC to Inverter Connection Kit' for both variants.

In addition the USS variant can also be connected via terminals 8 and 9 to a PC using any RS485/232 interface converter.

Set P0719 = 55 or set the command source P0700 = 5 and the frequency setpoint P1000 = 5 for complete inverter control when in STARTER mode.

---

### Note

When downloading parameter sets associated with different firmware releases using the STARTER tool, it should be noted that for the new parameters, the default value is entered.

---

### 3.4.2 Commissioning Overview

Depending on the variant and desired mode (see Table 3-3 on page 41), different possibilities are available for the advanced commissioning. Table 3-4 below gives an overview on how to:

- Change the motor base frequency
- Configure the frequency setpoint and command source only

Table 3-4 Commissioning Overview

Mode	Changing Motor Base Frequency (Section 3.4.3)	Basic Operation (Sections 4.1 and 4.2)	Advanced Commissioning
TERMINAL	Via DIP Switch only, see 3.3	a. <b>Frequency setpoint</b> : potentiometer on terminal 9. b. <b>Command source</b> : switches on terminals 3 – 6.	Not applicable
SERIAL	a. DIP switch, or b. P0100, or c. Manually enter data	a. <b>Frequency setpoint</b> : connect USS to terminals 8 & 9. b. <b>Command source</b> : connect USS to terminals 8 & 9. After reconfiguration, terminals 3 – 6 can also be used as command source.  <b>Note:</b> Ensure bus is terminated!	a. Quick commissioning, see Section 0 b. Factory default, see Section 3.4.5 c. External motor thermal overload protection, see Section 3.4.6
BOP	a. DIP switch, or b. P0100, or c. Manually enter data	a. <b>Frequency setpoint</b> : use arrow keys (MOP) b. <b>Command source</b> : use ON, OFF and REV keys.  <b>Note:</b> See 3.3.2 and 3.4.1 on page 42 for more information on using the BOP.	a. Quick commissioning, see Section 0 b. Factory default, see Section 3.4.5 c. External motor thermal overload protection, see Section 3.4.6 d. Parameter cloning, see Section 3.4.7
STARTER	a. DIP switch, or b. P0100, or c. Manually enter data	a. <b>Frequency setpoint</b> : see STARTER on-line help. b. <b>Command source</b> : see STARTER on-line help. After reconfiguration, terminals 3 – 6 can also be used as command source.	a. Quick commissioning, see Section 0 b. Factory default, see Section 3.4.5 c. External motor thermal overload protection, see Section 3.4.6 d. Parameters can be saved in file and can be written to other inverters. See STARTER documentation.

#### NOTES

- The frequency setpoint (P1000) and the command source (P0700) have both to be set correctly to operate the SINAMICS G110 inverter. Alternatively, P0719 can be set to a specific frequency setpoint and command source.
- Frequency setpoint and command source can be derived from different modes (e.g. the frequency setpoint is provided via the BOP with P1000 = 1 and the command source is set by the terminals with P0700 = 2).

### 3.4.3 Changing the Motor Base Frequency

The default motor base frequency of the SINAMICS G110 inverter is 50 Hz. In some parts of the world motors are designed for a base frequency of 60 Hz.

Changing the inverter motor base frequency is accomplished using three methods:

- A DIP switch is provided on the front of the inverter to select the required base frequency (see Section 3.3 on page 34).
- Parameter P0100 can be modified as described below.
- Manually entering the motor data from the motor rating label.



---

#### WARNINGS

- After a power cycle the inverter will read the base frequency from the DIP switch setting. This will overwrite the previous settings of P0100.
  - If P0100 is set to 0 or 1 then the DIP switch setting will be read and take priority over the software settings. However, if P0100 is set to 2, this value will take priority over the DIP switch, which may lead to unstable operation of the inverter should a 50 Hz frequency actually be required.
- 

#### Changing the motor base frequency via DIP switch

Changing the motor default base frequency can be accomplished by using the DIP switch which is provided on the front of the inverter as explained in Section 3.3 on page 34.

#### Setting the motor base frequency parameter (P0100)

The motor base frequency can be set by setting parameter P0100 as follows:

- P0100 = 0 (kW, 50 Hz) default
- P0100 = 1 (hp, 60 Hz)
- P0100 = 2 (kW, 60 Hz)

To change P0100 using the software the following procedure should be performed:

1. Stop the inverter.
2. Change P0010 to 1 (Commissioning Mode).
3. Change P0100 to the required setting.
4. Change P3900 to 1.

Changing P0100 will reset all the rated motor parameters as well as other parameters that depend upon the rated motor parameters as previously stated.

### 3.4.4 Quick Commissioning (P0010=1)

Quick commissioning is an easy way to optimally configure the SINAMICS G110 inverter to a specific motor. The motor data, taken from the motor rating label, is entered into the inverter and then the inverter calculates the dependent control and protection parameters.

An alternative to quick commissioning is parameter cloning (see page 49) that can be used if a large number of inverters are to be commissioned to the same specific motor.

#### NOTE

It is only possible to change motor parameters when quick commissioning is enabled (P0010=1).

It is **important** that parameter P0010 is used for commissioning and P0003 is used to select the number of parameters to be accessed. The P0003 parameter allows a group of parameters to be selected that will enable quick commissioning. Parameters such as Motor settings and Ramp settings are included.

At the end of the quick commissioning sequence, P3900 should be selected, which, when set to 1, will carry out the necessary motor calculations and clear all other parameters (not included in P0010=1) to the default settings. This will only happen in the Quick Commissioning mode.

Parameter P0010 is automatically reset to the value 0 when P3900 > 0. The inverter can only be run if P0010 has been set back to 0.

#### NOTE

We recommend commissioning is performed according to this scheme. Nevertheless an expert user is allowed to perform the commissioning with the filter functions of P0004.

### Motor data for parameterization

Figure 3-6 below indicates where to find the relevant motor data on the motor rating plate. Figure 3-6 is for illustration purposes only and the values within this figure should not be keyed into your inverter, rather the values from your own motor's rating plate should be keyed into the inverter.

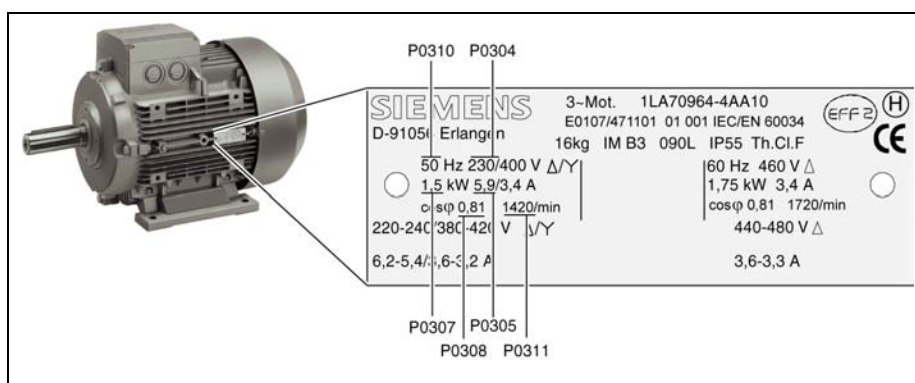
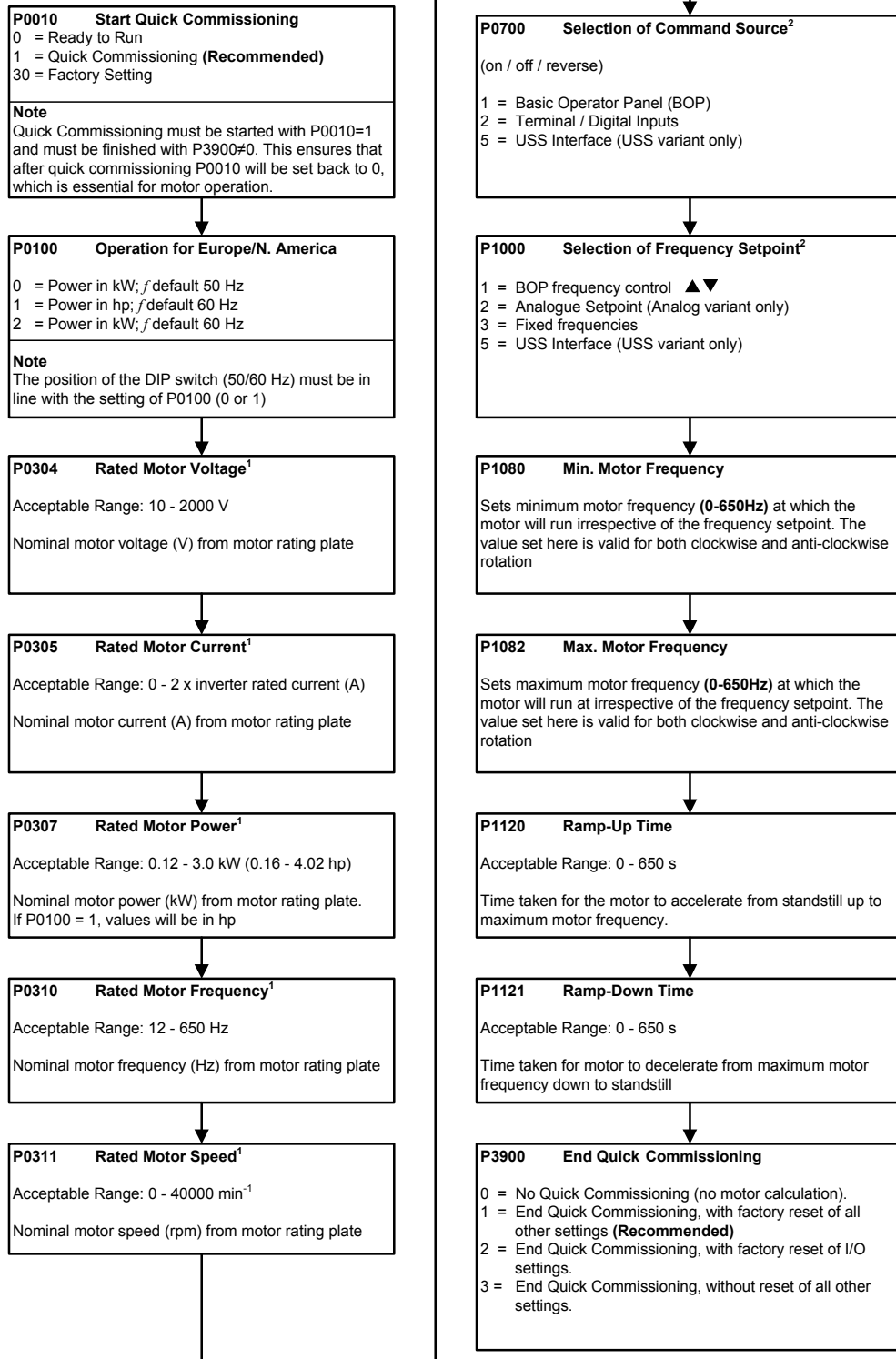

Figure 3-6 Typical Motor Rating Plate Example

**NOTES**

- P0308 & P0309 are only visible if P0003 = 3. For detailed information, please see the Parameter List.
  - P0307 indicates kW or HP depending upon the setting of P0100. For detailed information, please see the Parameter List.
  - Changing motor parameters is not possible unless P0010=1.
  - Ensure that the motor is configured correctly to the inverter, i.e. in the above example delta terminal connection is for 230 V.
-

**Flow chart Quick Commissioning (Level 1 Only – P0003=1)**



1. Motor related parameters - please refer to the motor rating plate.  
 2. Denotes parameters that contain more detailed lists of possible settings for use in specific applications. Please refer to the Parameter List.



### 3.4.5 Reset to Factory default

To reset all parameters to the factory default settings; the following parameters should be set as follows:

1. Set P0010=30.
2. Set P0970=1.

---

#### NOTE

The reset process can take up to 3 minutes to complete.

---

### 3.4.6 External Motor Thermal Overload Protection

When operated below rated speed, the cooling effect of fans fitted to the motor shaft is reduced. Consequentially, most motors require de-rating for continuous operation at low frequencies. To ensure that the motors are protected against overheating under these conditions, a PTC temperature sensor must be fitted to the motor and connected to the inverter control terminals as shown in Figure 3-7.

To enable the trip function set up one of the digital inputs using P0701 (DIN0) or P0702 (DIN1) or P0703 (DIN2) to a value of 29.

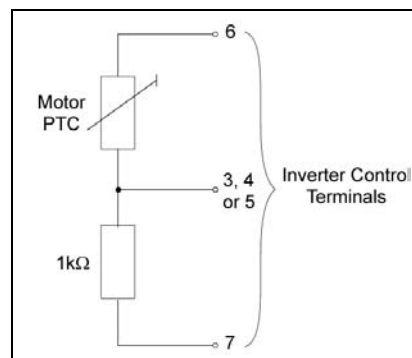

Figure 3-7 Motor Overload PTC

---

#### NOTE

Due to the electrical noise emitted by the PTC cables it is recommended that the PTC cables are routed parallel to the motor cables and not the inverter control cables.

---

### 3.4.7 Using the Digital Output

The digital output consists of an optically-isolated NPN transistor, with a rating of 24 V, 50 mA.

The optocoupler is normally used to indicate a fault, alarm or similar condition and can be programmed for many different purposes using parameter P0731. For details, please see the Parameter List.

The optocoupler is connected to the inverter terminal strip in the following way:

- Terminal No. 2 = Digital Output +
- Terminal No. 1 = Digital Output -

When the optocoupler is integrated into a control system, for example a PLC or a relay control, the direction of current inside the optocoupler (from positive to negative) must be observed.

It can therefore be connected to operate a warning light (LED) see Figure 3-8 (B) on page 50 or an auxiliary relay, see Figure 3-8 (A), providing that those ratings are not exceeded.

If the optocoupler is used to drive an auxiliary relay, make sure there is a commutation diode or a similar device to absorb the inductive energy.

If the optocoupler is used to drive an LED, make sure that the current is limited by means of a resistor.

Since the digital input of a PLC has a high impedance, the digital output can also be connected to the PLC using the internal power supply of the inverter using terminal 6 of the inverter, see Figure 3-8 (D) below. An external 24 V power supply is also permissible, see Figure 3-8 (C) below.

When the digital output is connected to a PLC with digital inputs having a high level at 24 V, for example the Simatic PLC or the Logo! Microcontroller, the following connection scheme is possible:

- Terminal 6 (Inverter's 24 V) is connected to Terminal 2 (Digital Output +)
- Terminal 1 (Digital Output -) is connected to the digital input terminal (e.g. I0.1) on the PLC.
- Terminal 7 (Inverter's reference voltage 0 V) is connected to the electronic ground of the PLC (e.g. 1M).

The sense of the optocoupler - "switch" (contacts open/contacts closed - respectively high active and low active) depends on the signal selected by P0731. For example, P0731=4 means drive running equals high active and is describe in the Parameter List. The sense of the optocoupler may be inverter by using P0748. Some typical configurations are shown in Figure 3-8 below.

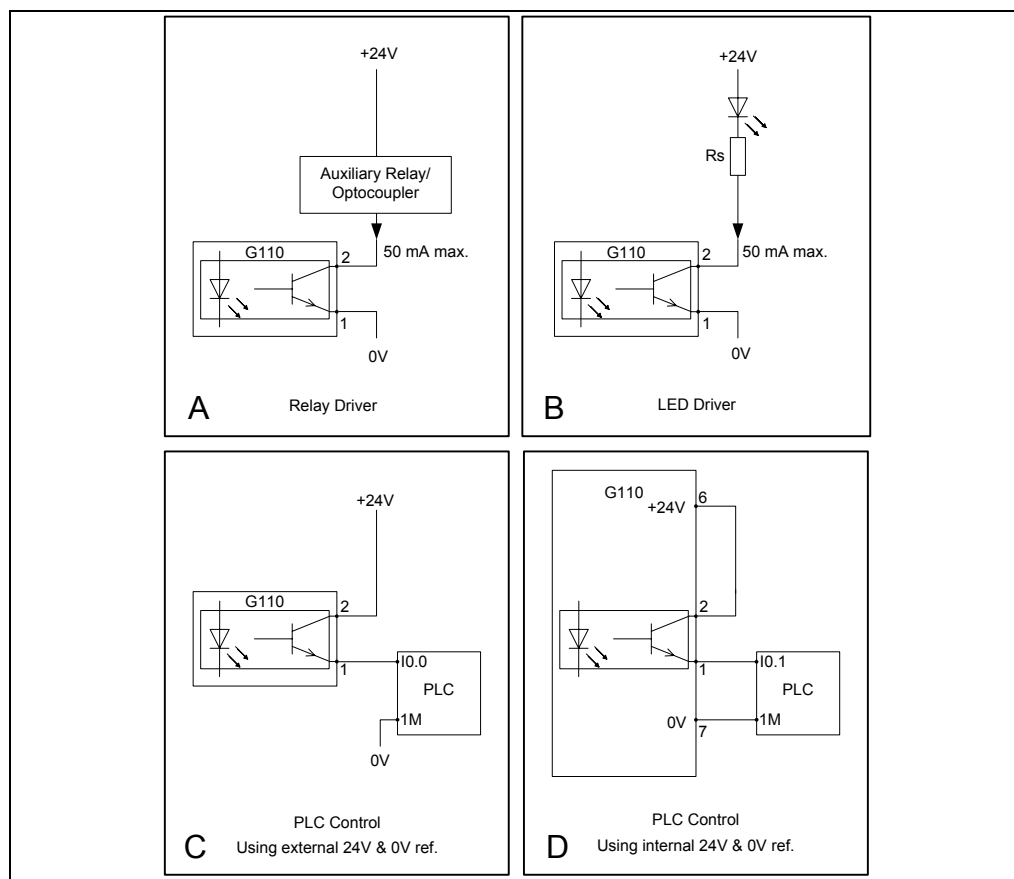

Figure 3-8 Typical Configurations of the Digital Output

### 3.4.8 Cloning Parameters with the BOP



#### Warning

During the download of parameters from the BOP to the inverter, the digital output may produce a spurious signal. Prior to performing a download from the BOP to the inverter appropriate counter-measures **must** be taken to ensure that any suspended load is secured, for example, by the use of external brakes or the load being lowered to ground level and secured.

A single parameter set can be uploaded from an inverter and then downloaded into another inverter. To clone a parameter set from one inverter to another, the following procedure should be performed:

1. Connect the Basic Operator Panel (BOP) to the inverter.
2. Ensure that it is safe to stop the inverter.
3. Stop the inverter.
4. Set parameter P0003 to 3.
5. Set parameter P0010 to 30 to enter Cloning Mode.
6. Set parameter P0802 to 1 to start the upload from the Inverter to the BOP.
7. During the upload "BUSY" will be displayed.
8. The BOP and the inverter will not react to any commands during upload.
9. If the upload has been completed successfully, the BOP display will return to normal and the inverter will return to a ready state.
10. If the upload has failed:
  - a. Attempt another upload.
  - or
  - b. Perform a factory reset.
11. The BOP can now be removed from the inverter.
12. Connect the BOP to the new inverter.
13. Ensure power is applied to the inverter.
14. Set parameter P0003 to 3.
15. Set parameter P0010 to 30 to enter Cloning Mode.
16. Set parameter P0803 to 1 to start the download from the BOP to the inverter.
17. During the download "BUSY" will be displayed.
18. During download the BOP and the inverter will not react to any commands during download.
19. If the download has been completed successfully, the BOP display will return to normal and the inverter will return to a ready state.
20. If the download has failed:
  - a. Attempt another download.
  - or
  - b. Perform a factory reset.
21. The BOP can now be removed from the inverter.

The following important restrictions should be considered when using the Cloning procedure:

- Only the current dataset is uploaded to the BOP.

- 
- Once the cloning procedure has started, it cannot be interrupted.
  - It is possible to copy data from inverters of different power and voltage ratings.
  - During download, if the data is not compatible with the inverter, the default values for the parameter will be written to the inverter.
  - During the cloning process any data already held by the BOP is overwritten.
  - If the download or upload of data fails, the inverter will not function correctly.

---

**Note**

1. After cloning parameters between differing variants of the SINAMICS G110 inverters (i.e. Analog to USS or USS to Analog) the following parameter must be checked:
    - P0719 – Selection of command and frequency setpoint
    - P1000 – Selection of frequency setpoint.
  2. When cloning parameter sets associated with different firmware releases using the BOP, it should be noted that for new parameters, the default value is entered.
-

## 4 Using the SINAMICS G110



### WARNINGS

- When operating electrical devices, it is impossible to avoid applying hazardous voltages to certain parts of the equipment.
- Emergency Stop facilities according to EN 60204 IEC 204 (VDE 0113) must remain operative in all operating modes of the control equipment. Any disengagement of the Emergency Stop facility must not lead to uncontrolled or undefined restart.
- Wherever faults occurring in the control equipment can lead to substantial material damage or even grievous bodily injury (i.e. potentially dangerous faults), additional external precautions must be taken or facilities provided to ensure or enforce safe operation, even when a fault occurs (e.g. independent limit switches, mechanical interlocks, etc.).
- SINAMICS G110 inverters operate at high voltages.
- Certain parameter settings may cause the inverter to restart automatically after an input power failure.
- Motor parameters must be accurately configured for motor overload protection to operate correctly above 5 Hz.
- This equipment is capable of providing internal motor overload protection in accordance with UL508C. Refer to P0610 and P0335, I<sup>2</sup>t is ON by default.
- This equipment is suitable for use in a circuit capable of delivering not more than 10,000 symmetrical amperes (rms), for a maximum voltage of 230V, when protected by an H or K type fuse, a circuit breaker or self-protected combination motor controller.
- This equipment **must** not be used as an 'emergency stop mechanism' (see EN 60204, 9.2.5.4)

### 4.1 Frequency Setpoint (P1000)

This parameter determines where the control signal for the frequency setpoint is obtained. The SINAMICS G110 has two default settings depending on the inverter variant.

#### Analog Variant

- Default Value: 2 – Terminal 9  
(AIN, 0...10 V)
- Other settings: see P1000 in the Parameter List

#### USS Variant

- Default Value: 5 – Terminals 8 and 9  
(RS485, USS protocol)
- Other settings: see P1000 in the Parameter List

## 4.2 Command Sources (P0700)

This parameter determines from which source the inverter receives the Start, Stop and Reverse commands. The SINAMICS G110 has two default settings depending on the inverter variant, see the Quick Commissioning Flowchart on page 48.

---

### NOTES

The ramp times and ramp-smoothing functions also affect how the motor starts and stops. For details of these functions, please refer to parameters P1120, P1121 and P1130 in the Parameter List.

---

### Starting the motor

#### Analog Variant

- Default value: 2 – Terminal 3 (DIN 0, high)
- Other settings: see P0701 to P0704 in the Parameter List

#### USS Variant

- Default value: 5 – Terminals 8 and 9 (RS485)
- Other settings: see P0701 to P0703 in the Parameter List

### Stopping the motor

There are several ways to stop the motor (for OFF1 – OFF 3 see page 55):

---

### NOTE

All OFF commands are active low.

---

#### Analog Variant

- Default value: 2 – Terminal 3 (DIN 0, low)
  - ◆ OFF1 2 – Terminal 3 (DIN 0, low)
  - ◆ OFF2 Off button on Basic Operator Panel, pressing the Off button once long (two seconds) or twice
  - ◆ OFF3 no standard setting
- Other settings: see P0700 to P0704 in the Parameter List

#### USS Variant

- Default value: 5 – Terminals 8 and 9 (RS485)
  - ◆ OFF1 Control word 1 (r0054), bit 00
  - ◆ OFF2 Off button on Basic Operator Panel, pressing the Off button once long (two seconds) or twice; control word 1 (r0054), bit 01
  - ◆ OFF3 Control word 2 (r0054), bit 02

## Reversing the motor

### Analog Variant

- Default value: 2 – Terminal 4 (DIN 1, high)
- Other settings: see P0701 to P0704 in the Parameter List

### USS Variant

- Default value: 5 – Terminals 8 & 9 (RS485); control word 1 (r0054), bit 11

## 4.3 Types of Control using the Terminals<sup>1</sup>

### Note

The automatic restart function (P1210) is disabled in the factory default setting. If the automatic restart function is required, the user must specifically enable this function. For details, please see the Parameter List.

The different types of control are enabled using parameter P0727 and selecting one of the following options:

### Default value:

- P0727 = 0: Siemens standard control (ON/OFF1, REV)

### Other settings:

- P0727 = 1: 2-wire control (ON\_FWD, ON\_REV)
- P0727 = 2: 3-wire control (FWDP, REVP, STOP)
- P0727 = 3: 3-wire control (ON\_PULSE, REV, OFF1/HOLD)

When any of the control functions are selected using P0727, the settings for the digital inputs (P0701 to P0704) are redefined as shown in Table 4-1 below.

Table 4-1 Redefined Digital Inputs

Settings P0701 - P0704	P0727=0 (Siemens Standard Control)	P0727=1 (2-wire Control)	P0727=2 (3-wire Control)	P0727=3 (3-wire Control)
1	ON/OFF1	ON_FWD	STOP	ON_PULSE
2	ON_REV/OFF1	ON_REV	FWDP	OFF1/HOLD
12	REV	REV	REVP	REV

"P" denotes "Pulse"; "FWD" denotes "Forward"; "REV" denotes "Reverse"

Each of the control methods shown in Table 4-1 will be explained individually.

<sup>1</sup> Valid for firmware 1.1

### 4.3.1 Siemens standard Control (P0727=0)

When P0727 = 0 there are two possibilities of control available using the following signals

1. ON/OFF1 and REV.
2. ON/OFF1 and ON REV/OFF1.

#### 4.3.1.1 ON/OFF1 and REV

##### Overview

This method allows the inverter to be started and stopped using the ON/OFF1 command and the direction of the inverter changed using the REV command. These commands can be assigned to any of the digital inputs through parameters P0701 to P0704.

The REV commands can be given at any time, independent of the frequency output of the inverter.

##### Function

The following description refers to Figure 4-1.

On receiving an ON/OFF1 command the inverter will run the motor in a forward direction and ramp-up the motor to the frequency setpoint.

When a REV command is issued, the inverter will ramp-down the frequency through 0 Hz and run the motor in the reverse direction. When the REV command is removed the inverter will ramp-up through 0 Hz and run in a forward direction until the frequency setpoint is reached.

When the ON/OFF1 command is removed, the inverter will stop the motor by performing an OFF1.

The REV command initiated by itself cannot start the motor.

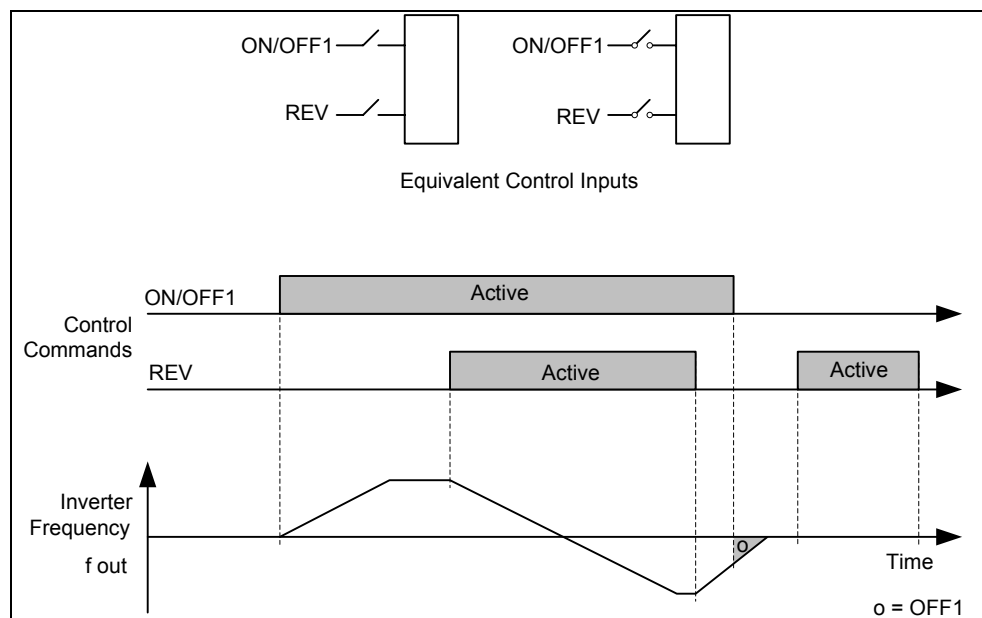

Figure 4-1 Siemens standard control using ON/OFF1 and REV



### 4.3.1.2 ON/OFF1 and ON\_REV/OFF1

#### Overview

This method allows the inverter to run the motor in a forward direction (run right) using the ON/OFF1 command and in the opposite direction (run left) using the ON\_REV/OFF1.

However, for a direction reversal the drive will first have to decelerate with OFF1 and when reaching 0 Hz the reverse signal can be applied.

#### Function

The following description refers to Figure 4-2.

The ramp down phase can be interrupted by start command in the same direction: if the drive was operating in forward and OFF1 was applied, an ON/OFF1 will work correctly and accelerate again the drive up to the setpoint speed. The same is valid for reverse and ON REV/OFF1

Giving a start command for the opposite direction of which the inverter frequency output is ramping down, the drive ignores the new setting and the drive will ramp down to 0 Hz and then remain at standstill.

Without any control signal enabled the drive will ramp down to a stop and remain at standstill.

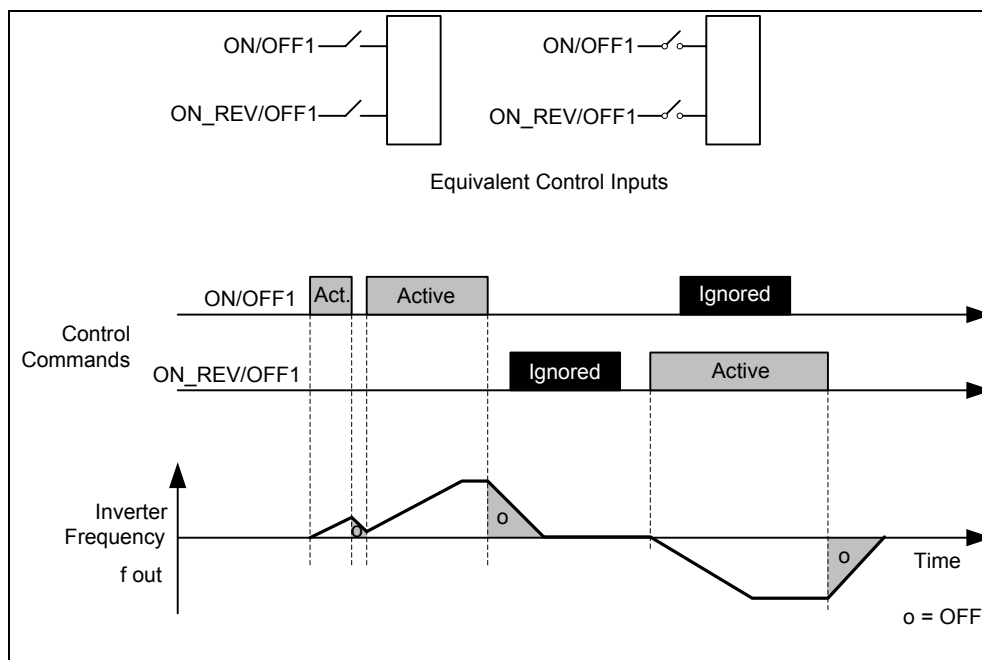

Figure 4-2 Siemens standard control using ON/OFF1 and ON\_REV/OFF1

### 4.3.2 2-wire Logic (P0727=1)

#### Overview

This method uses two maintained signals, ON\_FWD and ON\_REV which start/stop the drive and determine the direction of the motor.

The advantage of this method of control is that ON\_FWD and ON\_REV can be switched at any time, independently of the setpoint or frequency output or direction of rotation, and there is no requirement of the motor to ramp-down to 0 Hz before the command is performed.

#### Function

The following description refers to Figure 4-3.

With ON\_FWD closed and maintained closed the drive is ON and runs in forward direction.

Applying only ON\_REV (and keeping the contact closed) the drive is ON and runs in reverse direction.

If both signals are however enabled (contacts are closed) the drive will perform an OFF1 and ramp down to a stop.

If both signals are disabled the drive is in OFF1 state.

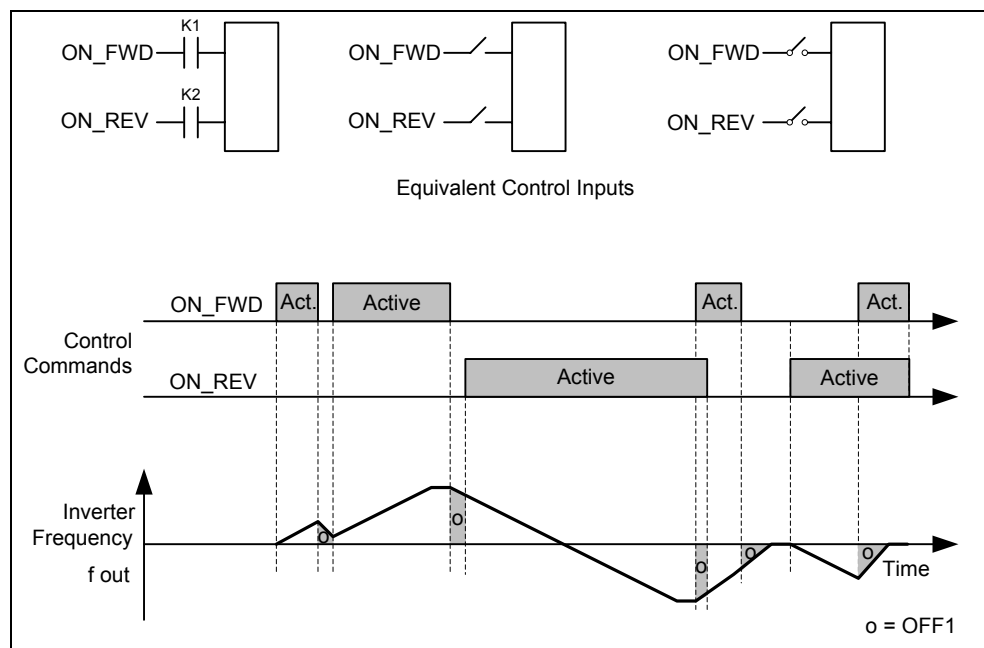

Figure 4-3 2-wire control using ON\_FWD and ON\_REV

### 4.3.3 3-wire Control (P0727=2)

#### Overview

This method uses three commands to control the operation of the motor:

1. STOP – Causes an OFF1 command to be performed by the inverter.
2. FWDP – Causes the motor to run in a forward direction (run right).
3. REVP – Causes the motor to run in the reverse direction (run left).

#### Function

The following description refers to Figure 4-4.

The STOP signal uses negative logic: Opening the contact or maintaining it open causes an OFF1 condition and the drive stops. The STOP contact will need to be maintained closed to start and run the drive.

Then a momentary closure (positive edge) of the FWDP or REVP contact latches and starts the drive.

A momentary closure (positive edge) of the FWDP contact will set the forward direction.

A momentary closure of the REVP contact will change to the reverse direction.

Closing FWDP and REVP will cause a Stop (OFF1).

The ramp down can be interrupted by a single new pulse FWDP or REVP.

A momentary closure of the FWDP or REVP contacts while the drive is operating in the respective direction will not cause any change.

Only by opening the STOP contact the drive will switch off regularly, apart from the special case that both signals FWDP and REVP are present.

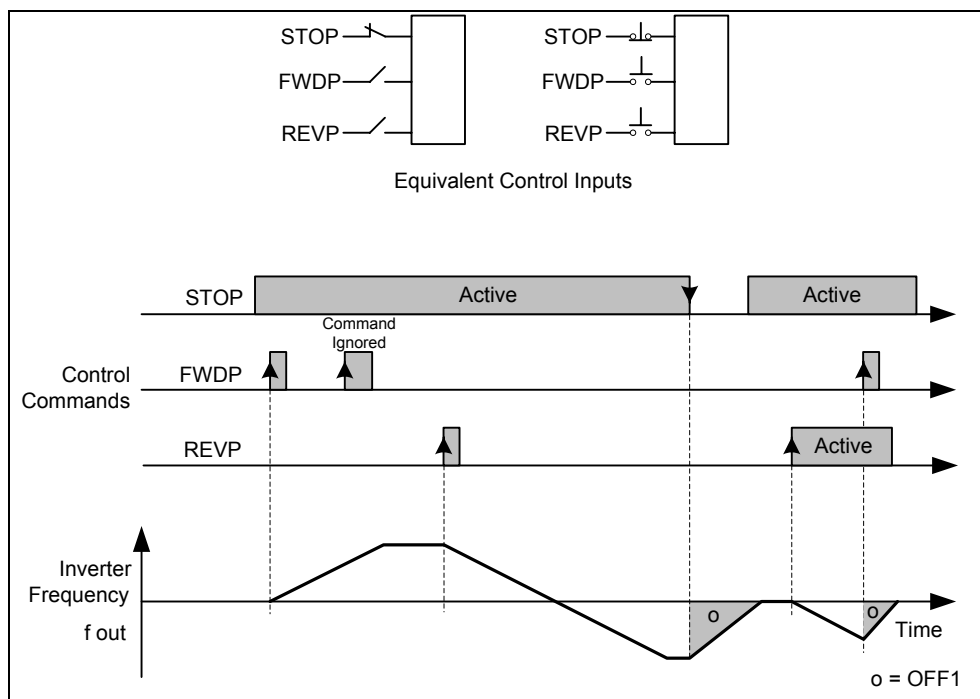

Figure 4-4 3-wire control using FWDP, REVP and STOP

### 4.3.4 3-wire Control (P0727=3)

#### Overview

There are three signals associated with this function:

1. OFF1/HOLD – Being maintained closed the opening of the contact will switch the drive OFF and cause a ramp down to 0 Hz.
2. ON\_PULSE – this will run the motor in a forward direction (run right).
3. REV – this will change the direction of the motor to reverse (run left).

#### Function

The following description refers to Figure 4-5.

The switch OFF1/HOLD uses negative logic: the contact will need to be maintained closed in order to switch the drive ON or keep it running.

A momentary closure (positive edge) of the ON\_PULSE switch latches and starts the drive if it was OFF before.

The direction can be determined and changed any time using the REV signal.

Opening or closing the ON\_PULSE switch while the drive runs has no effect.

Only enabling (i.e. Opening) OFF1/HOLD will unlatch the run-state and then stop the drive.

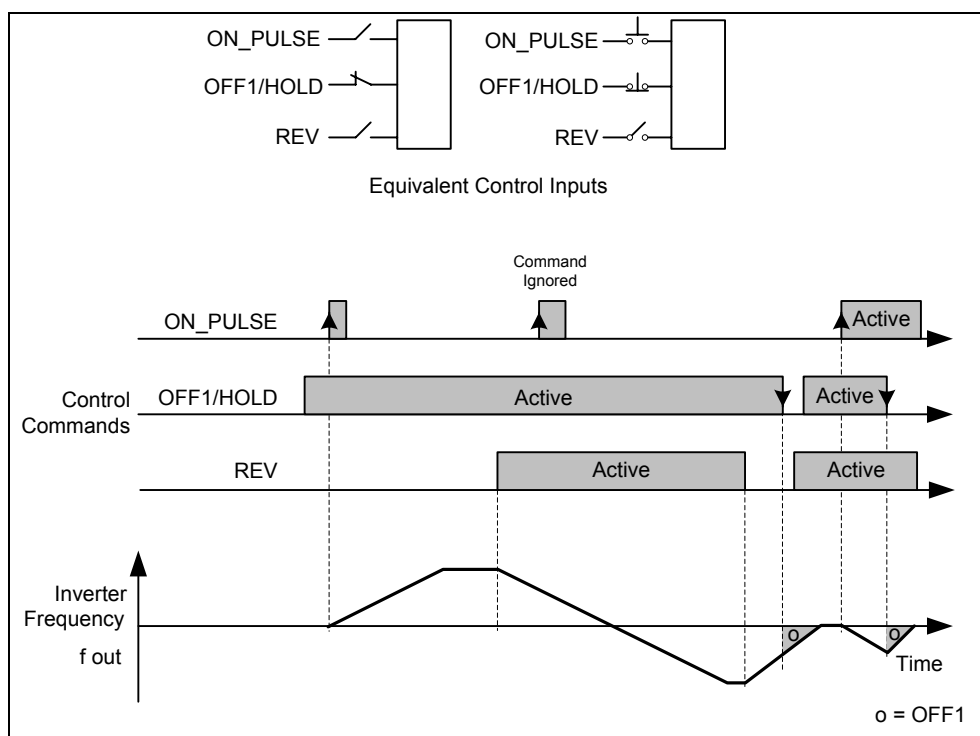

Figure 4-5 3-wire control using ON\_PULSE, OFF1/HOLD and REV

## 4.4 OFF and Braking Functions

### 4.4.1 OFF1

This command (produced by canceling the ON command) causes the inverter to come to a standstill at the selected ramp-down rate.

Parameter to change ramp-down time see P1121

---

#### NOTES

- ON and the following OFF1 command must have the same source.
  - If the ON/OFF1 command is set to more than one digital input, only the last set digital input is valid.
  - OFF1 can be combined with DC braking or Compound braking.
- 

### 4.4.2 OFF2

This command causes the motor to coast to a standstill (pulses disabled).

---

#### NOTE

The OFF2 command can be actuated from any command source simultaneously.

---

### 4.4.3 OFF3

An OFF3 command causes the motor to decelerate rapidly.

- Ramp down time: see P1135
- 

#### NOTE

OFF3 can be combined with DC braking or Compound braking.

---

### 4.4.4 DC braking<sup>2</sup>



---

#### Warning

During DC braking the components of the kinetic energy of the motor and the driven load are converted into thermal energy in the motor. If this power loss is too high or if the braking operation takes too long, then this can cause the motor to overheat.

---

DC braking is possible together with OFF1 and OFF3. A DC current is applied to stop the motor quickly and hold the shaft stationary until the end of the braking period. The stator resistance value must be entered into P0350 for the DC braking to work correctly.

- Enable DC braking: see P0701 to P0704
- Set DC braking period: see P1233
- Set DC braking current: see P1232
- Set DC braking start frequency: see P1234

---

<sup>2</sup> P1234 valid for firmware 1.1

**NOTE**

If no digital input is set to DC braking and P1233  $\neq$  0, DC braking will be active after every OFF1/OFF3 command with the time set in P1233, when the inverter output frequency (f out) has fallen below the DC braking start frequency set in P1234.

**4.4.5 Compound braking<sup>3</sup>****Warning**

For compound braking, DC braking is superimposed with regenerative braking. This means that the components of the kinetic energy of the motor and driven load are converted into thermal energy in the motor. If this power loss is too high or if the braking operation takes too long, then this can cause the drive to overheat!

Compound braking is enabled using P1236. DC braking is superimposed with regenerative braking, where the motor regenerates energy into the DC link as it brakes along a ramp. If the DC link voltage exceeds the compound switch-in threshold, then a DC current is impressed as a function of P1236.

Set the braking current: see P1236.

**Note**

Compound braking is de-activated if:

- ◆ Flying restart is active
- ◆ DC braking is active.

**4.5 Control Modes (P1300)**

The various modes of operation of the SINAMICS G110 control the relationship between the speed of the motor and the voltage supplied by the inverter. A summary of the control modes available are listed below:

- **Linear V/f control,** **P1300 = 0**  
Can be used for variable and constant torque applications, such as conveyors and positive displacement pumps.
- **Parabolic V/f control** **P1300 = 2**  
This mode can be used for variable torque loads, such as fans and pumps.
- **Multi-point V/f control** **P1300 = 3**  
This mode can be used to adapt the V/f control to special motor Torque-speed characteristics, e.g. in the case of synchronous motors.

**4.6 Faults and Alarms****Standard Inverter**

The fault state and warnings are indicated by the LED on the panel, see section 6.1 on page 65 for further information.

**Operator Panel Fitted**

If a Basic Operator Panel is fitted, the fault number and warning number, which is held in parameters r0947 or r2110 will be displayed should a fault or warning condition occur. For further details, please refer to the Parameter List.



<sup>3</sup> Valid for firmware 1.1

## 5 System Parameters

### 5.1 Introduction to SINAMICS G110 System Parameters

The parameters can only be changed by using the optional Basic Operator Panel (BOP) or the Serial Interface.

Parameters can be changed and set using the optional BOP to adjust the desired properties of the inverter, such as ramp times, minimum and maximum frequencies etc. The parameter numbers selected and the setting of the parameter values are indicated on the five-digit LCD display.

- Read only parameters are indicated with r instead of P.
- P0010 initiates “quick commissioning”.
- The inverter will not run unless P0010 is set to 0 after it has been accessed. This function is automatically performed if P3900 > 0.
- P0004 acts as a filter, allowing access to parameters according to their functionality.
- If an attempt is made to change a parameter that cannot be changed in this status, for example, cannot be changed whilst running or can only be changed in quick commissioning, then  will be displayed.
- **Busy Message**  
In some cases - when changing parameter values - the display on the BOP shows . This means the inverter is busy with tasks of higher priority.

#### 5.1.1 Access Levels

There are three access levels available to the user; Standard, Extended and Expert. The level of access is set by parameter P0003. For most applications, the Standard and Extended levels are sufficient.

The number of parameters that appear within each functional group (selected by P0004) depends on the access level set in parameter P0003. For further details regarding parameters, see the Parameter List.

## 5.2 Parameter Overview

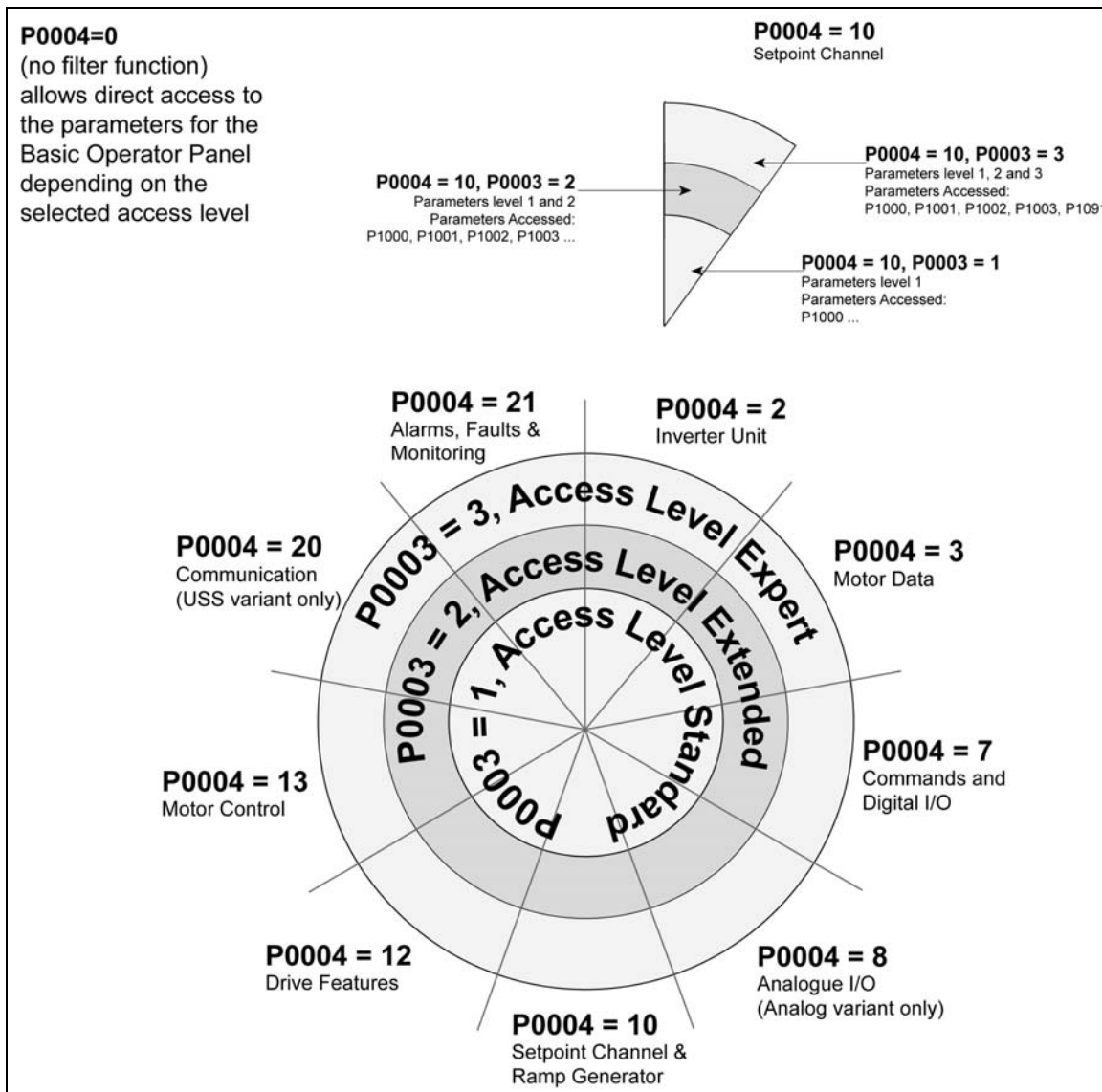

Figure 5-1 Parameter Overview

For a comprehensive description of all the parameters, please consult the SINAMICS G110 Parameter List.



## 6 Troubleshooting



### WARNINGS

- Repairs on equipment may only be carried out by **Siemens Service**, by repair centers **authorized by Siemens** or by **authorized** personnel who are thoroughly acquainted with all the warnings and operating procedures contained in this manual.
- Any defective parts or components must be replaced using genuine Siemens authorized parts.
- Risk of electric shock. The DC link capacitors remain charged for five minutes after power has been removed. **It is not permissible to open the equipment until 5 minutes after the power has been removed.**

### 6.1 Troubleshooting with the Standard Inverter LED

The following is a description of the fault and warning indications given by the LED on the Standard Inverter:

- Inverter Off/No supply: No LED lit.
- Power On/Ready: 200 ms On/800 ms Off
- Inverter Running OK: Steady LED
- General Warning: 800 ms On / 200 ms Off
- Fault Condition: 500 ms On / 500 ms Off

### 6.2 Troubleshooting with the BOP

If the display shows a fault or warning code, please consult the Faults and Warning section of the SINAMICS G110 Parameter List.

If the motor fails to start when the ON command has been given:

- Check that P0010 = 0.
- Check that a valid ON signal is present (see example on page 66).
- Check that P0700 = 1 (for BOP control) or P0700 = 2 (for digital input control) or P0700 = 5 (for USS input control – USS variant only) P0719 is set to the correct Command and Frequency Setpoint.
- Check that the setpoint is present (0 to 10V on Terminal 9) or the setpoint has been entered into the correct parameter, depending upon the setpoint source (P1000). See the Parameter List for further details.

If the motor fails to run after changing the parameters then:

1. Set P0010 = 30
2. Set P0970 = 1
3. Press **P** to reset the inverter to the factory default parameter values.
4. Use a switch between terminals **3** and **6** on the control board.
5. The inverter should now run to the setpoint defined by either the analogue input or transmitted via the USS serial link communications.

### NOTE

Motor data must relate to the inverter data power range and voltage.

### Checking for an ON Command

If, for example, DIN0 on terminal 3 was set-up to give an ON command, the following procedure would allow the user to check that an ON command is present:

1. Ensure the BOP is connected to the inverter.
2. Set P0003 = 3.
3. Select parameter r0722.
4. The Seven-segment display will indicate the active bits as follows:

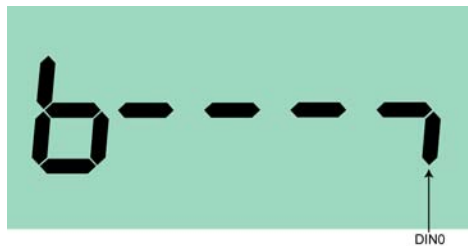

5. The lower mark on the right-hand side of the display indicates that DIN0 is active high, that is, an ON command is present.

If the active high bit is not present it indicates that a ON command is not present. In such a case it is necessary to check the hardware configuration to ensure that DIN0 was, in fact, set-up for the ON command.

In the case of ON/OFF control via the RS485 bus (USS protocol) the relevant bit (bit 02) of status word 1 (r0052) can be found in the following position:

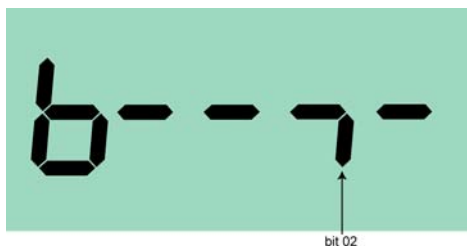

## 7 SINAMICS G110 Specifications

Table 7-1 SINAMICS G110 Performance Ratings

Feature	Specification			
Mains operating voltage and power ranges	200 V to 240 V ( $\pm 10\%$ ) 1AC	120 W to 3.0 kW		
Input frequency	47 to 63 Hz			
Output frequency	0 Hz to 650 Hz			
Cos $\varphi$	$\geq 0.95$			
Inverter efficiency	Below 750 W = 90% to 94%. On 750W units and higher $\geq 95\%$			
Overload capability	Overload current 1.5 x rated output current (i.e. 150 % overload capability) for 60 s; then 0.85 x rated output current for 240 s, cycle time 300 s			
User Power Supplies	24 V on pins 6 and 7 (50 mA unregulated supply); 10 V on pins 8 and 10 (5 mA)			
Inrush current	less than rated input current			
Control method	linear V/f, quadratic V/f, multipoint characteristic (programmable V/f)			
Pulse frequency	8 kHz (standard); 2 kHz to 16 kHz (in 2 kHz steps)			
Fixed frequencies	3 programmable			
Skip frequency	1 programmable			
Setpoint resolution	0.01 Hz digital, 0.01 Hz serial, 10 bit analog (motor potentiometer 0.1 Hz)			
Digital inputs	3 programmable digital inputs, non-isolated; PNP, SIMATIC-compatible, low < 5V: high > 10 V: maximum input voltage 30 V.			
Analog input (Analog Variant)	1 for setpoint (0 V to 10 V, scaleable or for use as 4th digital input)			
Digital output	1 isolated optocoupler output (24 Vdc, 50 mA resistive), NPN transistor type			
Serial interface (USS Variant)	RS-485, for operation with USS protocol			
Motor cable length	max. 25 m (shielded)	max. 50 m (unshielded)		
Electromagnetic compatibility	All units available with internal EMC filter for Category C2 (restricted availability) – PDS installations (specifies limits equivalent to EN55011, Class A). In addition all units with integral filters for screened motor cables up to 5 m will meet the limits to EN55011 Class B.			
Braking	Compound Braking (firmware 1.1 only), DC Braking			
Protection level	IP20			
Temperature range	-10 °C to +40 °C (up to +50 °C with derating)			
Storage temperature	-40 °C to +70 °C			
Humidity	95 % (non-condensing)			
Operational altitudes	up to 1000 m above sea level without derating			
Protection features for	<ul style="list-style-type: none"> <li>• under-voltage</li> <li>• short circuits</li> </ul>	<ul style="list-style-type: none"> <li>• over-voltage</li> <li>• stall prevention</li> </ul>	<ul style="list-style-type: none"> <li>• J2t motor thermal protection</li> <li>• Inverter overload</li> </ul>	<ul style="list-style-type: none"> <li>• earth faults</li> <li>• motor overtemperature</li> </ul>
Conformity with standards	UL, cUL, CE, c-tick			
CE marking	Conformity with EC low voltage directive 73/23/EC			
Dimensions and weights (without options)	Frame size (FS)	H x W x D mm (Inches)	Approx. Weight kg (lbs)	
			Unfiltered	Filtered
	A up to 370W	150 x 90 x 116 (5.9 x 3.5 x 4.6)	0.7 (1.5)	0.8 (1.8)
	A 550 & 750W	150 x 90 x 131 (5.9 x 3.5 x 5.2)	0.8 (1.8)	0.9 (2.0)
	A Flat Plate Version up to 370W	150 x 90 x 101 (5.9 x 3.5 x 3.9)	0.6 (1.3)	0.7 (1.5)
	A Flat Plate Version 550 W & 750 W	150 x 90 x 101 (5.9 x 3.5 x 3.9)	0.7 (1.5)	0.8 (1.8)
	B 1.1 kW & 1.5 kW	160 x 140 x 142 (6.3 x 5.5 x 5.6)	1.4 (3.1)	1.5 (3.3)
	C 2.2 kW	181 x 184 x 152 (7.1 x 7.2 x 6.0)	1.9 (4.2)	2.1 (4.6)
	C 3.0 kW	181 x 184 x 152 (7.1 x 7.2 x 6.0)	2.0 (4.4)	2.2 (4.9)

Table 7-2 Control Terminals Screwless  
Type – Wire Sizes

Minimum Cable Cross Section	[mm <sup>2</sup> ]	1
	[AWG]	18
Maximum Cable Cross Section	[mm <sup>2</sup> ]	1.5
	[AWG]	16

Table 7-3 Tightening Torques – Power Terminals

Frame Size	Screw Type	Power & PE Terminals	
		Nm	lbf.in
FSA	M3.5	0.96	8.50
FSB	M4	1.50	13.30
FSC	M5	2.25	19.91

Table 7-4 SINAMICS G110 Specifications, Frame Size A;  
input voltage 1 AC 200 V – 240 V, ± 10 %, power range 120 W - 750 W

Frame Size		A	A	A	A	A
<b>Motor Output Rating</b>	[kW]	0.12	0.25	0.37	0.55	0.75
	[hp] <sup>1</sup>	0.16	0.33	0.5	0.75	1.0
<b>Order No.</b>		6SL3211-				
<b>Unfiltered</b>	<b>analog</b>	0AB11-2UA0*	0AB12-5UA0*	0AB13-7UA0*	0AB15-5UA0*	0AB17-5UA0*
	<b>USS</b>	0AB11-2UB0*	0AB12-5UB0*	0AB13-7UB0*	0AB15-5UB0*	0AB17-5UB0*
	<b>flat plate analog</b>	0KB11-2UA0*	0KB12-5UA0*	0KB13-7UA0*	0KB15-5UA0*	0KB17-5UA0*
	<b>flat plate USS</b>	0KB11-2UB0*	0KB12-5UB0*	0KB13-7UB0*	0KB15-5UB0*	0KB17-5UB0*
<b>Filtered</b>	<b>analog</b>	0AB11-2BA0*	0AB12-5BA0*	0AB13-7BA0*	0AB15-5BA0*	0AB17-5BA0*
	<b>USS</b>	0AB11-2BB0*	0AB12-5BB0*	0AB13-7BB0*	0AB15-5BB0*	0AB17-5BB0*
	<b>flat plate analog</b>	0KB11-2BA0*	0KB12-5BA0*	0KB13-7BA0*	0KB15-5BA0*	0KB17-5BA0*
	<b>flat plate USS</b>	0KB11-2BB0*	0KB12-5BB0*	0KB13-7BB0*	0KB15-5BB0*	0KB17-5BB0*
<b>Output Current</b> <sup>2</sup>	[A]	0.9	1.7	2.3	3.2	3.9 (40°C)
<b>Input Current</b> <sup>3</sup>	[A]	2.3	4.5	6.2	7.7	10.0
<b>Recommended Fuse</b>	[A]	10.0	10.0	10.0	10.0	16.0
		3NA3803	3NA3803	3NA3803	3NA3803	3NA3805
<b>Input Cable</b>	[mm <sup>2</sup> ]	1.0 – 2.5	1.0 – 2.5	1.0 – 2.5	1.0 – 2.5	1.5 – 2.5
	[AWG]	16 – 12	16 – 12	16 – 12	16 – 12	14 – 12
<b>Output Cable</b>	[mm <sup>2</sup> ]	1.0 – 2.5	1.0 – 2.5	1.0 – 2.5	1.0 – 2.5	1.0 – 2.5
	[AWG]	16 – 12	16 – 12	16 – 12	16 – 12	16 – 12

<sup>1</sup> The horsepower (hp) ratings are obtained by comparison to the Siemens 1LA6 and 1LA7 motors and not NEMA/UL rated motors.

<sup>2</sup> Current data applies for an ambient temperature of 50°C unless otherwise specified

<sup>3</sup> The value applies to the rated mains voltage of 230 V

\* Indicates the last digit of the Order No. may change due to modifications of hardware or software in the product.

Table 7-5 Frame Sizes B and C;  
input voltage 1 AC 200 V – 240 V,  $\pm 10\%$ , power range 1.1 kW - 3.0 kW

Frame Size		B	B	C	C
<b>Motor Output Rating</b>	[kW] <sup>1</sup>	1.1	1.5	2.2	3.0
	[hp] <sup>1</sup>	1.5	2.0	3.0	4.0
<b>Order No.</b>		6SL3211-			
<b>Unfiltered</b>	<b>analog</b>	0AB21-1UA0*	0AB21-5UA0*	0AB22-2UA0*	0AB23-0UA0*
	<b>USS</b>	0AB21-1UB0*	0AB21-5UB0*	0AB22-2UB0*	0AB23-0UB0*
<b>Filtered</b>	<b>analog</b>	0AB21-1AA0*	0AB21-5AA0*	0AB22-2AA0*	0AB23-0AA0*
	<b>USS</b>	0AB21-1AB0*	0AB21-5AB0*	0AB22-2AB0*	0AB23-0AB0*
<b>Output Current</b> <sup>2</sup>	[A]	6.0	7.8 (40°C)	11.0	13.6 (40°C)
<b>Input Current</b> <sup>3</sup>	[A]	14.7	19.7	27.2	32.0
<b>Recommended Fuse</b>	[A]	20.0	25.0	35.0	50.0
		3NA3807	3NA3810	3NA3814	3NA3820
<b>Input Cable</b>	[mm <sup>2</sup> ]	2.5 – 6.0	2.5 – 6.0	4.0 – 10	6.0 – 10
	[AWG]	12 – 10	12 – 10	11 – 8	10 – 8
<b>Output Cable</b>	[mm <sup>2</sup> ]	1.5 – 6.0	1.5 – 6.0	2.5 – 10	2.5 – 10
	[AWG]	14 – 10	14 – 10	12 – 8	12 – 8

<sup>1</sup> The horsepower (hp) ratings are obtained by comparison to the Siemens 1LA6 and 1LA7 motors and not NEMA/UL rated motors.

<sup>2</sup> Current data applies for an ambient temperature of 50°C unless otherwise specified

<sup>3</sup> The value applies to the rated mains voltage of 230 V

\* Indicates the last digit of the Order No. may change due to modifications of hardware or software in the product.

Table 7-6 Power losses SINAMICS G110  
(230 V) inverters

Frame size	Output Power (kW)	Losses (W)
A	0.12	22
A	0.25	28
A	0.37	36
A	0.55	43
A	0.75	54
B	1.1	86
B	1.5	118
C	2.2	174
C	3	210

\*The losses given in Table 7-6 are applicable for units fitted with 25 m of screened cable

Table 7-7 Harmonic currents Single Phase 230 V

Rated Output (kW)	Fundamental Amps	3 <sup>rd</sup> Amps	5 <sup>th</sup> Amps	7 <sup>th</sup> Amps	9 <sup>th</sup> Amps	11 <sup>th</sup> Amps	13 <sup>th</sup> Amps
0.12	1.18	1.05	0.9	0.76	0.58	0.568	0.508
0.25	2.26	2.06	1.77	1.50	1.32	1.20	1.02
0.37	3.19	2.26	2.26	2.12	1.83	1.56	1.22
0.55	4.28	3.86	3.18	2.44	1.82	1.42	1.12
0.75	4.52	4.51	3.98	2.98	2.42	1.90	1.44
1.1	8.12	7.80	5.92	4.12	2.96	2.20	1.52
1.5	11.0	9.04	6.40	4.08	2.92	2.16	1.48
2.2	15.7	12.6	8.56	4.56	3.00	2.44	1.28
3.0	19.1	14.4	7.8	3.6	3.28	2.36	0.88

Table 7-8 Derating with Pulse Frequencies

Rated output (kW)	Rated output current in A*							
	For a pulse frequency of							
	2kHz	4kHz	6kHz	8kHz	10kHz	12kHz	14kHz	16kHz
0.12	0.9	0.9	0.9	0.9	0.9	0.9	0.9	0.9
0.25	1.7	1.7	1.7	1.7	1.7	1.7	1.7	1.7
0.37	2.3	2.3	2.3	2.3	2.3	2.3	2.3	2.3
0.55	3.2	3.2	3.2	3.2	3.0	2.7	2.5	2.2
0.75 (40°C)	3.9	3.9	3.9	3.9	3.6	3.3	3.0	2.7
0.75	3.2	3.2	3.2	3.2	3.0	2.7	2.5	2.2
1.1	6.0	6.0	6.0	6.0	5.9	5.7	5.6	5.4
1.5 (40°C)	7.8	7.8	7.8	7.8	7.6	7.4	7.2	7.0
1.5	6.0	6.0	6.0	6.0	5.9	5.7	5.6	5.4
2.2	11.0	11.0	11.0	11.0	10.8	10.5	10.2	9.9
3.0 (40°C)	13.6	13.6	13.6	13.6	13.3	12.9	12.6	12.3
3.0	11.0	11.0	11.0	11.0	10.8	10.5	10.2	9.9

The derating for these units are at 50°C unless otherwise stated.

## 8 Options

The following accessories are available as options for your SINAMICS G110 Inverter. For more details please refer to the catalogue or contact your local Siemens sales office if you require assistance.

### Variant Dependent Options

- Supplementary filter for Class B operation
- Low leakage Class B filter
- Line commutating choke

### Variant Independent Options

- Basic Operator Panel (BOP)
- DIN Rail Mounting Kit
- PC to inverter connection kit
- STARTER software commissioning tool.





## 9 Electro-Magnetic Compatibility (EMC)

### 9.1 Electro-Magnetic Compatibility (EMC)

All manufacturers / assemblers of electrical apparatus which “performs a complete intrinsic function and is placed on the market as a single unit intended for the end user” must comply with the EMC directive EC/89/336.

There are two routes for the manufacturer/assembler to demonstrate compliance:

#### 9.1.1 Self-Certification

This is a manufacturer's declaration that the European standards applicable to the electrical environment for which the apparatus is intended have been met. Only standards that have been officially published in the Official Journal of the European Community can be cited in the manufacturer's declaration.

#### 9.1.2 Technical Construction File

A technical construction file can be prepared for the apparatus describing its EMC characteristics. This file must be approved by a ‘Competent Body’ appointed by the appropriate European government organization. This approach allows the use of standards that are still in preparation.

---

#### Note

The SINAMICS G110 inverter is designed to be used only by professional end users with EMC knowledge. It is not designed for users that do not have EMC knowledge.

These operating instructions give sufficient information which enables the professional end user to implement all the necessary measures to ensure electromagnetic compatibility.

---

### 9.1.3 EMC Directive Compliance with Harmonics Regulations

From 1st January 2001 all electrical apparatus covered by the EMC Directive will have to comply with EN 61000-3-2 "Limits for harmonic current emissions (equipment input  $\leq$  16A per phase)".

All Siemens variable speed drives of the SINAMICS G110 range, which are classified as "Professional Equipment" within the terms of the standard, fulfill the requirements of the standard.

Special considerations for 120W to 550W drives with 230V 1ac mains supplies when used in non-industrial applications

For units in this voltage and power range the following warning applies:

*"This equipment requires supply authority acceptance for connection to the public supply network"*. Please refer to EN 61000-3-12 sections 5.3 and 6.4 for further information. Units connected to Industrial Networks<sup>4</sup> do not require connection approval (see EN 61800-3, section 6.1.2.2).

The harmonic current emissions from these products are described in the table below:

Table 9-1 Harmonic currents

Rating	Typical Harmonic Current (A)					Typical Harmonic Current (%)					Typical Voltage Distortion		
											Distribution Transformer Rating		
	10kVA	100kVA	1MVA										
	3 <sup>rd</sup>	5 <sup>th</sup>	7 <sup>th</sup>	9 <sup>th</sup>	11 <sup>th</sup>	3 <sup>rd</sup>	5 <sup>th</sup>	7 <sup>th</sup>	9 <sup>th</sup>	11 <sup>th</sup>	THD (%)	THD (%)	THD (%)
120W 230V 1AC	1.05	0.9	0.76	0.58	0.57	89	76	64	49	48	0.631	0.063	0.0063
250W 230V 1AC	2.06	1.77	1.50	1.32	1.20	91	78	66	58	53	1.297	0.13	0.013
370W 230V 1AC	2.26	2.26	2.12	1.83	1.56	71	71	66	57	49	1.673	0.167	0.0167
550W 230V 1AC	3.86	3.18	2.44	1.82	1.42	90	74	57	43	33	1.85	0.185	0.0185

The allowed harmonic currents for "professional equipment" with an input power  $>1\text{kW}$  are not yet defined. Therefore, any electrical apparatus containing the above drives which has an input power  $>1\text{kW}$  will not require connection approval.

Alternatively, the necessity to apply for connection approval can be avoided by fitting the input chokes recommended in the technical catalogues (except 550W 230V 1ac units).

<sup>4</sup> Industrial Networks are defined as those which do not supply buildings used for domestic purposes.

### 9.1.4 Three general cases of EMC performance are applicable as detailed below

#### Case 1: General Industrial

Compliance with the EMC Product Standard for Power Drive Systems EN 61800-3 for use in **Second Environment (Industrial)** and **Restricted Distribution**.

Table 9-2 Case 1 - General Industrial

EMC Phenomenon		Standard	Level
Emissions	Radiated Emissions	EN 55011	Level Group 1, Class A
	Conducted Emissions	EN 61800-3	Limits are equivalent to EN55011, Class A, group 2
Immunity:	Electrostatic Discharge	EN 61000-4-2	8 kV air discharge
	Burst Interference	EN 61000-4-4	2 kV power cables (Level 3), 1 kV control (Level 3)
	Radio Frequency Electromagnetic Field	EN 61000-4-3	26-1000 MHz, 10 V/m

#### Case 2: Filtered Industrial

This level of performance will allow the manufacturer/assembler to self-certify their apparatus for compliance with the EMC directive for the industrial environment as regards the EMC performance characteristics of the power drive system. Performance limits are as specified in the Generic Industrial Emissions and Immunity standards EN 50081-2 and EN 61000-6-2.

Table 9-3 Case 2 - Filtered Industrial

EMC Phenomenon		Standard	Level
Emissions:	Radiated Emissions	EN 55011	Level Group 1, Class A
	Conducted Emissions	EN 61800-3	Limits are equivalent to EN55011, Class A, group 2
Immunity:	Supply Voltage Distortion	EN 61000-2-4	
	Voltage Fluctuations, Dips, Unbalance, Frequency Variations	EN 61000-2-1	
	Electrostatic Discharge	EN 61000-4-2	8 kV air discharge
	Burst Interference	EN 61000-4-4	2 kV power cables (Level 3), 2 kV control (Level 4)
	Radio Frequency Electromagnetic Field, amplitude modulated	EN 61000-4-3	80-1000 MHz, 10 V/m, 80% AM, power and signal lines

**Case 3: Filtered - for residential, commercial and light industry**

This level of performance will allow the manufacturer / assembler to self-certify compliance of their apparatus with the EMC directive for the residential, commercial and light industrial environment as regards the EMC performance characteristics of the power drive system. Performance limits are as specified in the generic emission and immunity standards EN 50081-1 and EN 50082-1.

Table 9-4 Case 3 - Filtered for Residential, Commercial and Light Industry

EMC Phenomenon		Standard	Level
<b>Emissions</b>	Radiated Emissions *	EN 55011	Level for equipment Class B
	Conducted Emissions	EN 61800-3	Category C1: level equivalent to EN55011, Class B Category C2: level equivalent to EN55011, Class A
<b>Immunity:</b>	Supply Voltage Distortion	EN 61000-2-4	
	Voltage Fluctuations, Dips, Unbalance, Frequency Variations	EN 61000-2-1	
	Electrostatic Discharge	EN 61000-4-2	8 kV air discharge
	Burst Interference	EN 61000-4-4	2 kV power cables (Level 3), 2 kV control (Level 4)

\* These limits are dependent on the inverter being correctly installed inside a metallic switchgear enclosure. The limits will not be met if the inverter is not enclosed.

**NOTE**

To achieve these performance levels, you must not exceed the default Pulse frequency.

Table 9-5 Compliance Table

Model	Remarks
<b>Case 1 – General Industrial</b>	
6SL3211-0****-*U*0	Unfiltered units, all voltages and powers. The product standard EN 61800-3 + A11 for “Adjustable speed electrical power drive systems – Part3: EMC product standard including specific test methods” specifies limits for conducted emissions, which cannot be matched from unfiltered inverters in the 2 <sup>nd</sup> environment. For Category C3 <sup>5</sup> PDS installations, filtered inverters (as described under case 2) have to be installed. The use of unfiltered inverters in an industrial installation is only possible if it forms part of a system which includes power-line filtering at the “system level”
<b>Case 2 – Filtered Industrial</b>	
6SL3211-0****-*A*0 6SL3211-0****-*B*0	All units with integral filters for screened motor cables up to: Class A – FSA – 10 m (32.80 ft) Class A – FSB and FSC – 25 m (82.02 ft)
<b>Case 3 – Filtered for residential, commercial and light industry</b>	
6SL3211-0****-*A*0 6SL3211-0****-*B*0	Category C2 <sup>6</sup> : All units with integral filters for screened motor cables upto 10 m (32.80 ft) Class A, FSA and upto 25 m (82.02 ft) (Class A, FSB and FSC). For PDS installations in Category C2 (restricted availability) the following warning label is required: “This is a product of Category C2 according to IEC 61800-3. In a domestic environment this product may cause radio interference in which case mitigation measure may be required” In addition all units with integral filters for screened motor cables upto 5 m (16.40 ft) will meet the limits to EN55011 Class B.
* denotes any value is allowed.	

**NOTE**

It is possible to use unfiltered inverters in a Category C1<sup>7</sup> PDS installation (general availability) when combined with a low leakage filter and a secondary metallic enclosure. In addition the “16 kHz pulse frequency” and ‘Y’ – capacitor link not to be removed must be observed for frame sizes B and C only.

<sup>5</sup> Category C3: Power Drive System (PDS) of rated voltage less than 1000V, intended for use in the second environment.

<sup>3</sup> Category C2: Power Drive System (PDS) of rated voltage less than 1000V, which when used in the first environment is intended to be installed and commissioned only by a professional.

<sup>7</sup> Category C1: Power Drive System (PDS) of rated voltage less than 1000V, intended for use in the first environment.



## A Removal of 'Y' Capacitor Link

To use the SINAMICS G110 FSB and FSC on ungrounded supplies the 'Y' capacitor (cap) link must be removed as follows:

1. Ensure the inverter has been disconnected from all power supplies.
2. The unit should not be opened until 5 minutes after the power has been removed.
3. Remove the EMC earth screw as shown **1**.
4. Lift the inverter cover as shown **2**.
5. Locate the 'Y' Capacitor Link as shown in **3**.
6. Cut the 'Y' Cap link with an appropriate pair of wire-cutters.
7. Ensure that the cut ends of the link are separated by more than 2 mm.
8. Replace the unit cover, ensuring no cables have been trapped or damaged.
9. Tighten the EMC earth screw (0.8 Nm/7.08 lbf.in).

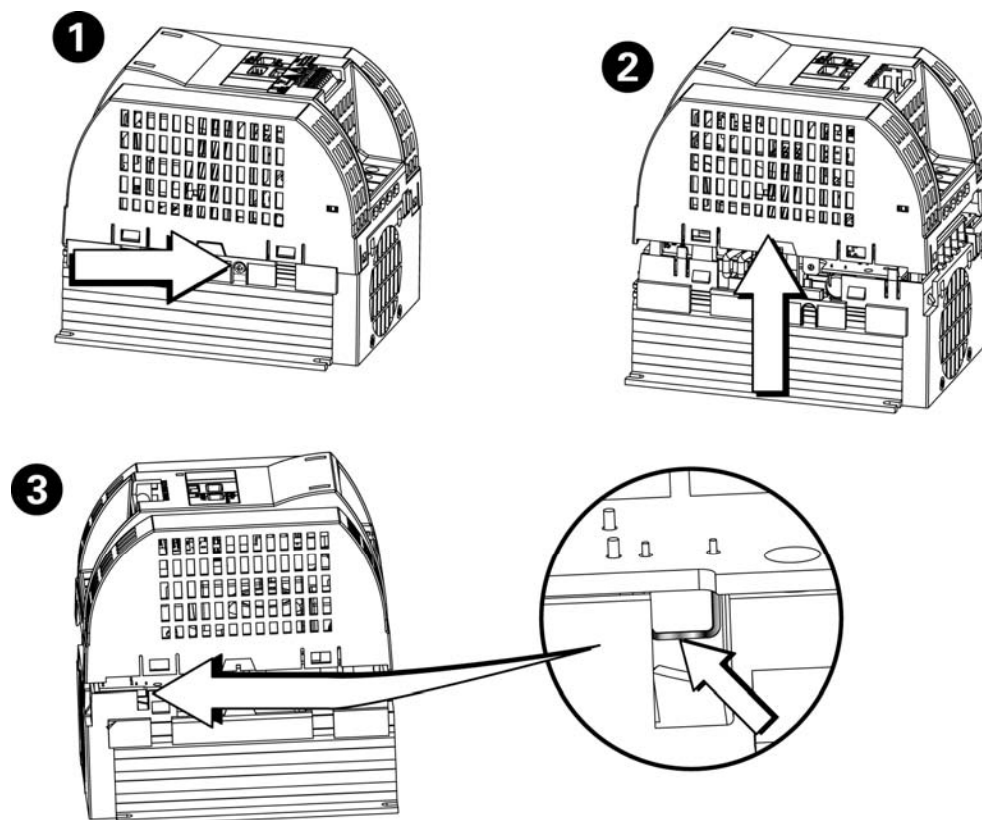

## B DIN Rail Mounting Kit

The DIN Rail Mounting Kit is an optional accessory for the SINAMICS G110 inverter. It must be ordered as a separate item using the following Order Numbers:

- For FSA: 6SL3261-1BA00-0AA0.
- For FSB: 6SL3261-1BB00-0AA0.

The kit consists of the following items:

- 1 x Metal base plate
- 6 - FSA, 8 - FSB x M4 screws (maximum torque 2.0 Nm [17.7 lbf.in])
- 2 x Saddle-clamps
- 1 - FSA, 2 - FSB x DIN Rail fixing bolt.

In order to fit the DIN Rail Kit to the inverter and mount the inverter onto a DIN rail, the following procedure should be performed:

---

### Note

- The DIN Rail Mounting Kit procedure outlined below refers to Figure B-1 on page 81.
  - The installation procedure outlined below is for guidance only. Full and detailed installation instructions will be delivered with the actual DIN Rail Mounting Kit.
- 

1. Fit the DIN Rail fixing bolt as shown in Step 1.
2. Ensure that the fixing bolt is seated correctly into the cutout guides as shown in Step 2.
3. Using the 2 or 4 M4 screws, secure the inverter to the metal base plate as shown in Step 3.
4. Clip the top recess of the metal base plate onto the DIN rail as shown in Step 4 in the direction as indicated by the arrow labeled 1.
5. Push the front of the inverter to secure the inverter to the DIN rail as shown in Step 4 in the direction as indicated by the arrow labeled 2.
6. Check to ensure that the inverter is secured correctly onto the DIN rail.
7. Prepare the cables and wiring for the inverter as shown in Step 5, ensuring that the cable sheath has been removed to allow a good grounding when secured by the saddle-clamps.
8. Using four M4 screws, secure the cables to the metal base plate as shown in Step 5 utilizing the saddle-clamps.

### Removal of Inverter from DIN Rail

The release mechanism for DIN Rail Mounting Kit is located near the bottom of the metal base plate, just above the saddle-clamps (see Step 6 in Figure B-1).

To release the inverter from the DIN rail you will require one or two 6 mm (¼") flat-bladed screwdriver.

To release the inverter from the DIN rail the following procedure should be performed:

1. Ensure the inverter is powered down.
2. Grasp the front of the inverter.
3. Insert the screwdriver in the release mechanism and push the release mechanism in a downward direction.



4. Holding the front of the inverter, pull the inverter forward and upwards to release it from the DIN rail.

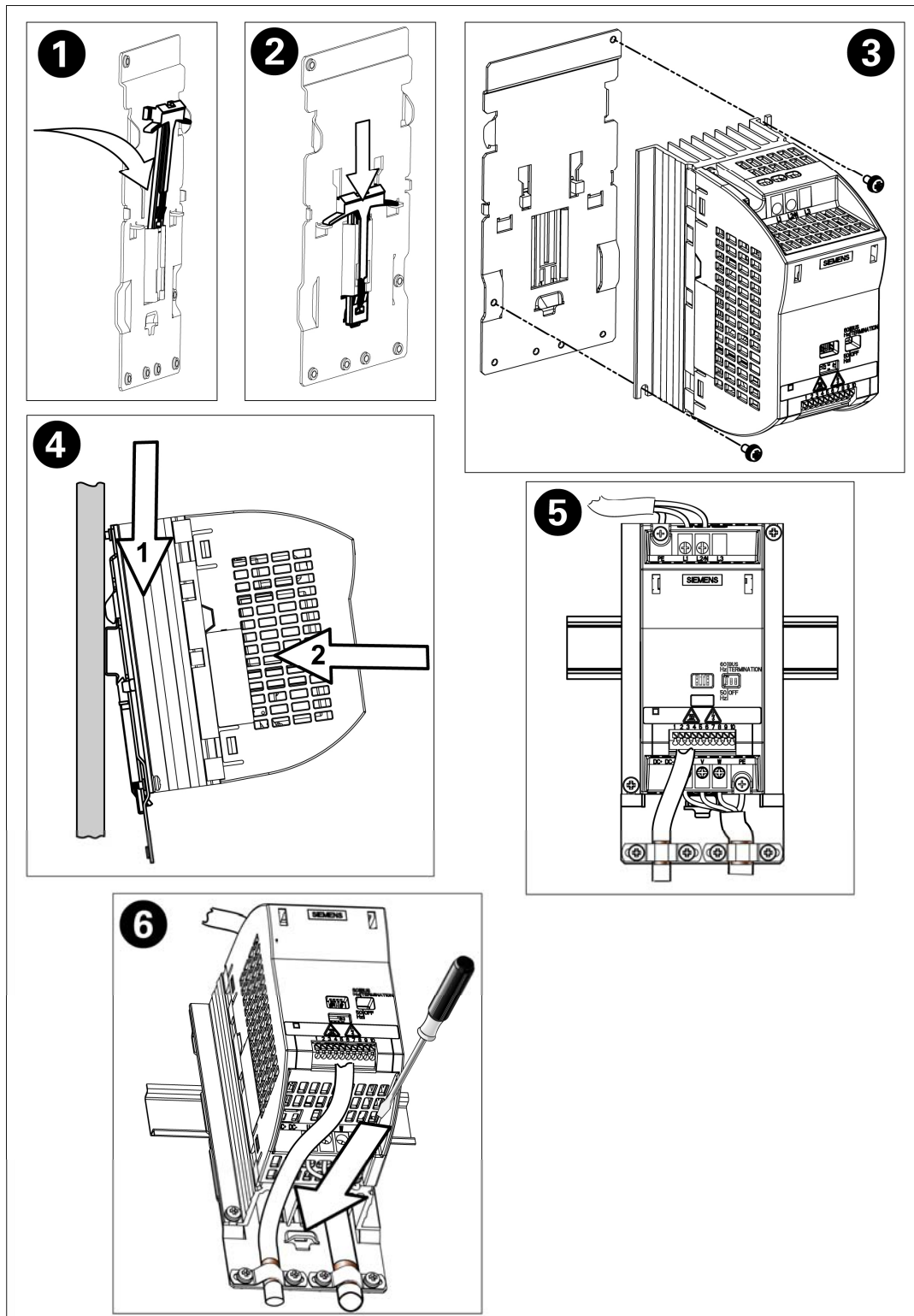
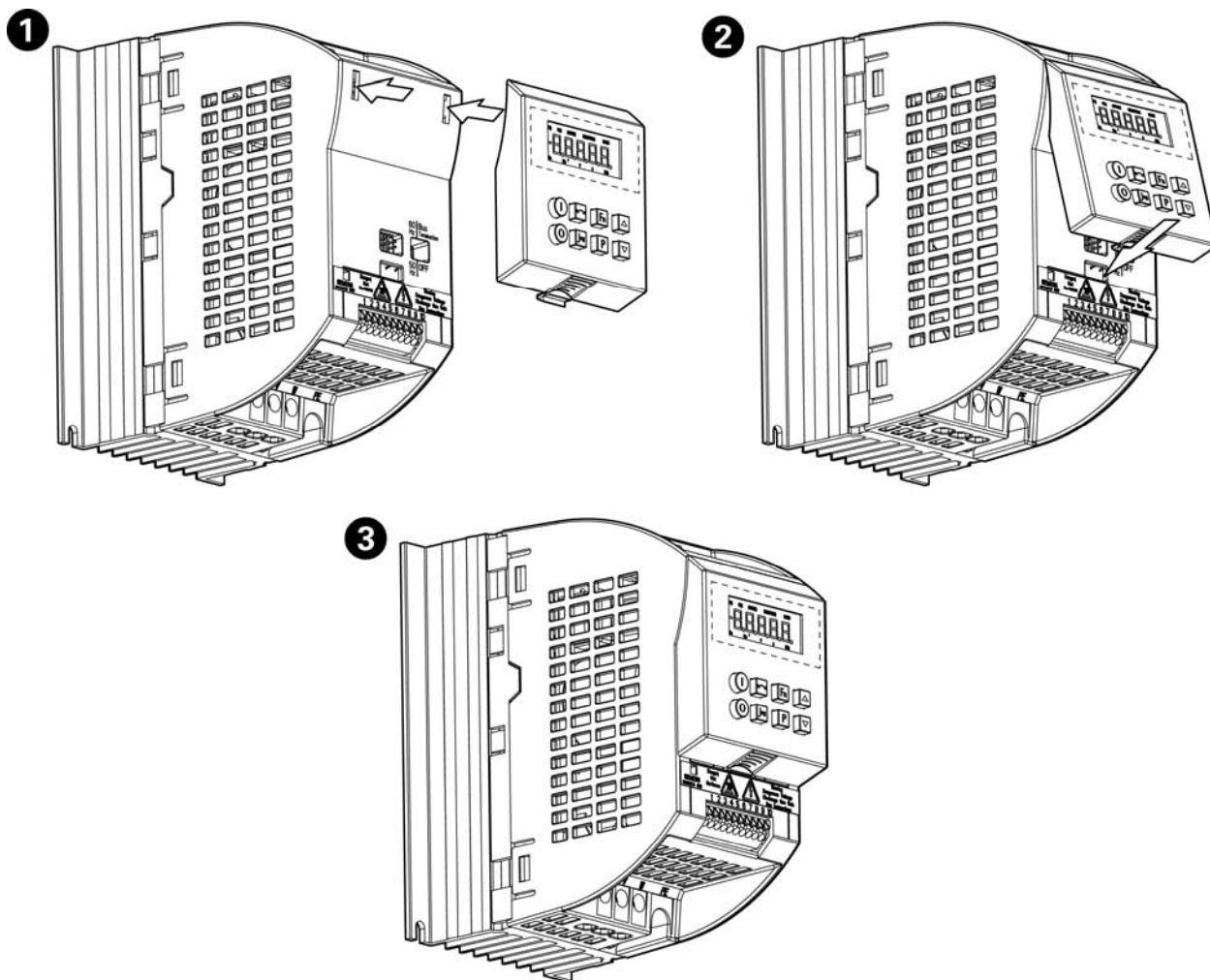











Figure B-1 Installing the DIN Rail Mounting Kit (FSA)

## C Fitting the Basic Operator Panel



## D Description of the BOP

Panel/Button	Function	Effects
	Indicates Status	The LCD displays the settings currently used by the converter.
	Start motor	Pressing the button starts the inverter. This button is disabled by default. To enable this button set P0700 = 1.
	Stop motor	OFF1 Pressing the button causes the inverter to come to a standstill at the selected ramp down rate. OFF2 Pressing the button twice (or once long) causes the motor to coast to a standstill. This function is always enabled.
	Change direction	Press this button to change the direction of rotation of the motor. Reverse is indicated by a minus (-) sign or a flashing decimal point. Disabled by default, to enable set P0700 = 1.
	Jog motor	Pressing this button while the inverter has no ON command causes the motor to start and run at the preset jog frequency. The inverter stops when the button is released. Pressing this button when the inverter/motor is running has no effect.
	Functions	This button can be used to view additional information. Pressing and holding the button for 2 seconds from any parameter during operation, shows the following: 1. DC link voltage (indicated by d – units V). 2. Output voltage (indicated by o – units V). 3. Output frequency (Hz). 4. The value selected in P0005. Additional presses will toggle around the above displays. A short press of the button will acknowledge a fault condition. <b>Jump Function</b> From any parameter (rXXXX or PXXXX) a short press of the Fn button will immediately jump to r0000, you can then change another parameter, if required. Upon returning to r0000, pressing the Fn button will return you to your starting point.
	Access parameters	Pressing this button allows access to the parameters.
	Increase value	Pressing this button increases the displayed value.
	Decrease value	Pressing this button decreases the displayed value.

## E Applicable Standards



---

### European Low Voltage Directive

The SINAMICS G110 product range complies with the requirements of the Low Voltage Directive 73/23/EC as amended by Directive 98/68/EC. The units are certified for compliance with the following standards:

EN 50178      Electronic equipment for use in power installations

EN 60204-1    Safety of machinery - Electrical equipment of machines

---

### European EMC Directive

When installed according to the recommendations described in this manual, the SINAMICS G110 fulfils all requirements of the EMC Directive as defined by the EMC Product Standard for Power Drive Systems EN61800-3.

---

### Underwriters Laboratories



UL and CUL LISTED POWER CONVERSION EQUIPMENT for use in a pollution degree 2 environment

---

### ISO 9001

Siemens plc operates a quality management system, which complies with the requirements of ISO 9001.

---

### NOTICE:

#### ***Machinery Directive***

The devices are suitable for installation in machines. According to the machinery directive 89/392/EC the compliance requires a separate certificate of conformity.

This certificate must be issued by the firm which constructs the plant or puts the machinery on the market.

---

## F List of Abbreviations

AC	Alternating current
AD	Analog digital converter
ADC1	Analog input 1
BOP	Basic operator panel
CP	Cold Plate Assembly
CPM	Controlled Power Module
CT	Constant torque
DC	Direct current
DIN	Digital input
DIP	Dual in-line package (switch)
DOUT	Digital output
EC	European Community
ELCB	Earth leakage circuit breaker
EMC	Electro-magnetic compatibility
EMI	Electro-magnetic interference
FAQ	Frequently asked questions
FCL	Fast current limit
FF	Fixed frequency
Fn	Function button
FS	Frame size
GSG	Getting started guide
I/O	Input and output
IGBT	Insulated gate bipolar transistor
JOG	Jog button
LCD	Liquid crystal display
LED	Light emitting diode
MOP	Motor potentiometer
NPN	Negative-Positive-Negative Transistor Type
OPI	Operating instructions
PDS	Power drive system
PLC	Programmable logic controller
PLI	Parameter list
PNP	Positive-Negative-Positive Transistor Type
PTC	Positive temperature coefficient
QC	Quick commissioning
RCCB	Residual current circuit breaker
RCD	Residual current device
RFG	Ramp function generator
RFI	Radio-frequency interference
RPM	Revolutions per minute
USS	Universal serial interface
VT	Variable torque



# Index

## 2

2-wire control · 55

2-wire Logic · 58

## 3

3-wire control · 55

3-wire Control · 59, 60

## A

Abbreviations · 85

Access Levels · 63

Advanced commissioning · 33

Advanced Commissioning · 40

Altitude · 18

Ambient operating conditions · 18

Analog Variant · 33

Applicable standards

European EMC Directive · 84

European Low Voltage Directive · 84

ISO 9001 · 84

Underwriters Laboratories · 84

Atmospheric pollution · 19

## B

Basic commissioning · 33

Basic Commissioning · 34

Basic operation

external motor thermal overload

protection · 46

BOP · 42

Bus Termination · 36, 37

## C

Changing parameters with the Basic

Operator Panel · 38

Changing single digits in parameter values · 39

Changing the motor base frequency · 34

Changing the Motor Base Frequency · 45

Cloning Parameters · 51

Commissioning · 31, 39

Commissioning Overview · 44

Compound braking · 62

Contact address · 5

Control Modes · 62

## D

DC braking · 61

Default settings · 35, 36

Derating · 19, 70

Digital Output · 49

Dimensions · 20

Dimensions and Torques · 22

DIN Rail Mounting Kit · 80

DIP switch · 45

Drill pattern for SINAMICS G110 · 21

## E

Electrical Installation · 23

Electro-Magnetic Compatibility

general · 73

self-certification · 73

technical construction file · 73

Electro-Magnetic Interference · 27

avoiding EMI · 27

Electromagnetic radiation · 18

EMC · 73

EMC Directive Compliance · 74

EMC performance

filtered for residential, commercial and light industry · 76

filtered industrial class · 75

general industrial class · 75

EMI · 27

Error codes · 65

## F

Fault codes

with the Basic Operator Panel fitted · 65

with the Standard Inverter LED · 65

Faults and warnings

BOP fitted · 62

Standard Inverter · 62

Features · 15

Fitting the Basic Operator Panel · 82

Foreword · 5

Frequency Setpoint · 53

## H

Harmonic currents · 74

Humidity Range · 18

## I

Installation

after a period of storage · 17

Internet Home Address · 5

Inverter block diagram · 32

## L

Linear V/f control · 62

Long cables

operation with · 24

## M

Main characteristics · 15

Mechanical Installation · 20

Modes of Operation Overview · 41

Motor connections · 24

Motor data · 46

Multi-point V/f control · 62

- O**
- Operation
  - starting and stopping the motor · 54, 61
- Operation with
  - long cables · 24
  - Residual Current Device · 24
  - ungrounded IT supplies · 23
- Operator Panel · 37, 42
  - warnings and faults states · 36
- Operator panels
  - changing the Basic Operator Panel · 82
- Overheating · 19
- Overview · 15, 17
- Overvoltage · 19
- P**
- Parameter Overview · 64
- Parameters
  - system parameters · 63
- Performance characteristics · 16
- Power and motor connections · 24
  - single phase · 27
- Power connections · 24
- Power Losses
  - output graphs · 18
- Protection characteristics · 16
- Pulse Frequencies · 70
- Q**
- Quadratic V/f control · 62
- Qualified personnel · 6
- Quick commissioning · 46
- R**
- Removal of 'Y' Capacitor Link · 79
- Reset to Factory default · 40, 44, 49
- Residual Current Device
  - operation with · 24
- S**
- Safety instructions · 7
- Serial · 42
- Shock · 18
- Siemens standard Control · 56
- SINAMICS G110
  - available options · 71
  - general · 15
  - main characteristics · 15
  - performance characteristics · 16
  - protection characteristics · 16
  - specifications · 67
- Specifications · 68
- T**
- Technical Support · 5
- Temperature · 18
- Terminal · 42
- Trip Levels · 19
- Troubleshooting · 65
- Types of Control · 55
- U**
- Using the Digital Output · 49
- USS Variant · 33
- V**
- Variant Dependent Options · 71
- Variant Independent Options · 71
- W**
- Warning and fault status · 40
- Warnings, cautions & notes
  - commissioning · 8
  - definitions · 6
  - dismantling & disposal · 9
  - general · 7
  - operation · 9
  - repair · 9
  - transport & storage · 8
- Water hazard · 19
- Wire Sizes & Terminal Torques · 68
- Wiring Guidelines EMI · 28



**Suggestions and/or Corrections**

<b>To:</b> Siemens AG Automation & Drives Group SD PM 4 P.O. Box 3269  D-91050 Erlangen Federal Republic of Germany	<b>Suggestions</b>  <b>Corrections</b> For Publication/Manual:  SINAMICS G110 Operating Instructions
Email: <a href="mailto:documentation.sd@siemens.com">documentation.sd@siemens.com</a>	User Documentation
<b>From</b> Name: <b>Company/Service Department</b> Address:  Telephone: Telefax:	<b>Operating Instructions</b>  Order Number: 6SL3298-0AA11-0BP0  Date of Issue: 04/2005  Should you come across any printing errors when reading this publication, please notify us on this sheet. Suggestions for improvement are also welcome.





Siemens AG  
Automation & Drives  
Standard Drives  
Postfach 3269, D – 91050 Erlangen  
Germany

[www.siemens.com](http://www.siemens.com)

© Siemens AG 2005  
Subject to change without prior notice  
6SL3298-0AA11-0BP0

Printed in Germany