

Using MICROWAVE SOLUTIONS Ltd Motion Detector Units

1. Introduction

The Microwave Solutions Ltd MDU (Motion Detector Unit) is a miniature microwave doppler radar sensor optimised for low power consumption, short range (<30 metres) and low cost.

A wide selection of sensors, including those shown in Table 1, are currently available.

Table1

Model	Style	Frequency	Primary Application	Standards
MDU11xx	Plastic	9.90GHz 10.525GHz 10.587Ghz 10.687GHz	France, Italy, Portugal Holland, Belgium, Italy UK indoor/outdoor UK indoor	EN 300 440 EN 300 440 EN 300 440 EN 300 440
MDU1720	Small Pcb style	10.525GHz	USA Indoor	FCC Part 15
MDU17xx	Small ETS	9.35GHz 9.90GHz 10.525GHz 10.587Ghz 10.687GHz	Germany France, Italy, Portugal Holland, Belgium, Italy UK indoor/outdoor UK indoor	EN 300 440 EN 300 440 EN 300 440 EN 300 440
MDU2000	Miniature	10.525GHz 10.587GHz	Holland, Belgium, Italy UK indoor/outdoor	EN 300 440 EN 300 440

Individual data sheets are available for all sensors on our website or by request.

The MDU emits a low level X Band microwave signal which is reflected from all objects within its coverage area. If any of the objects that the signal has bounced off is moving towards or away from the sensor the frequency of the reflected signal received back by the sensor will be increased or decreased from the frequency of the transmitted signal by the Doppler effect.

The MDU compares the transmitted and received frequencies and produces an IF output signal, the frequency of which is proportional to the velocity of the object. The amplitude of this signal is a complex function of the size and reflectivity of the object and its distance from the MDU, as well as the characteristics of the MDU. A brief discussion of range is contained in Appendix 1 "Radar Range Equation".

External signal processing circuitry (not provided with the unit) is required to amplify this signal and analyse its frequency spectrum. If the signal strength is above a threshold level, and has the required frequency spectrum an output signal can be generated.

In order to conserve power it is usual for the MDU to be pulsed on and off rapidly so that it is only transmitting for approximately 5% of the time. As well as reducing power consumption, this also reduces the average power transmitted. This does not reduce the ability of the MDU to detect moving objects.

Using MICROWAVE SOLUTIONS Ltd. Motion Detector Units

2. Circuit Description

The Microwave Solutions Ltd Motion Detector Unit contains a dielectric resonator stabilised microwave FET oscillator, providing a frequency and amplitude stable signal at the operating frequency of the unit. The power from this oscillator is filtered to reduce harmonic and spurious signals and is split into two approximately equal amplitude signals.

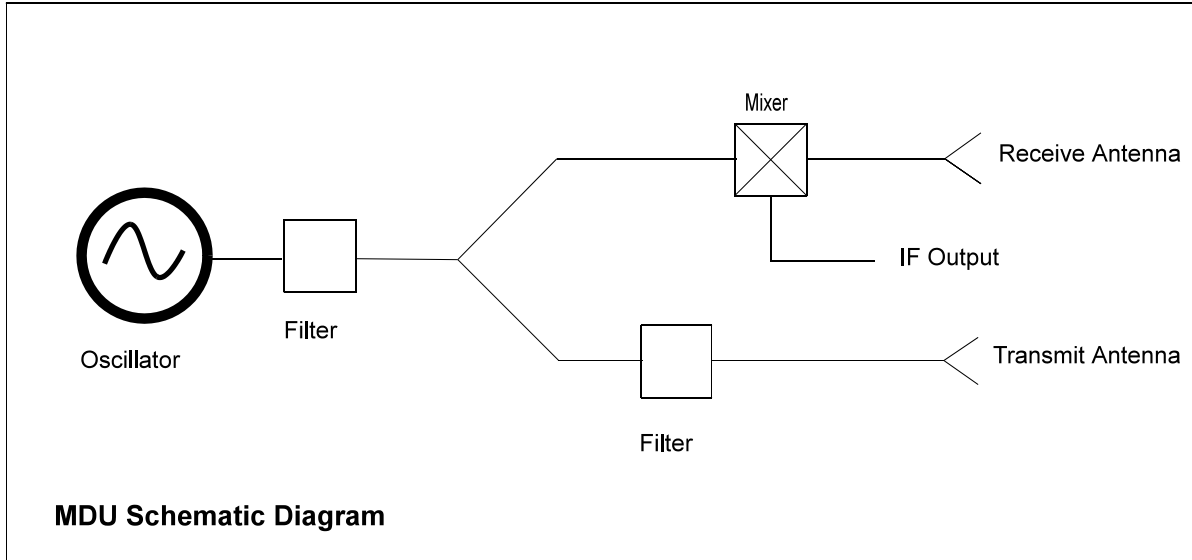

One of these signals is further filtered and feeds the transmit antennas of the unit, illuminating the volume to be protected. The other signal is fed to the local oscillator input of a balanced mixer as the reference signal against which the Doppler return signal is compared.

The Doppler return signal, reflected from the target is collected by the receive antennas and coupled to the RF input of the balanced mixer, where it is compared with the transmitted signal. The Doppler frequency is extracted and is available at the IF output of the unit for signal processing.

3. Oscillator

The oscillator requires $5V \pm 0.25V$ applied to the +5V terminal of the device. If the oscillator is powered continuously (CW mode) the current consumption is typically 50mA. For lower power consumption the unit can be operated in pulsed mode by supplying the oscillator with 5V pulses with a typical pulse width of 30 μ seconds and repetition rate of 1-3KHz. A duty cycle of 3-10% will reduce the average current consumption to 1.5-5mA. Duty cycles as low as 0.1% are possible, giving an average current consumption of 50 μ A.

The peak value of the pulse voltage must lie between 4.75 and 5.25V and the flatter the pulse top the better the detection capability of the MDU will be. Under these conditions pulse chirp will be less than 1MHz. It is also important to ensure the power supply does not inject noise within the Doppler frequency range of interest on the module.

Application of a peak voltage in excess of 5.25V will degrade the reliability of the unit and may cause it to transmit RF power at frequencies outside the authorised bands.

Using MICROWAVE SOLUTIONS Ltd. Motion Detector Units

4. RF Power Levels

The RF power levels radiated by the MDU are extremely low under all conditions, and many orders of magnitude below the maximum recommended levels in normal operating modes.

The maximum transmitted power is less than 15mW. This power is distributed within the coverage pattern of the MDU, with a maximum power density is 1mW/cm² at a distance of 5mm from the front face of the unit, reducing to 0.72μW/cm² at a distance of 1 metre.

Any equipment containing an MDU as the sole emitter of electromagnetic fields is therefore exempt from the testing requirements for human exposure to electromagnetic fields under the safety aspects of the R&TTE directive per EN 62479:2010

The emissions from the MDU are also below the recommended maximum permissible exposure levels specified in IEEE standard C95.1-1991. In fact under normal pulsed operating conditions, measured at a distance of 1 metre in front of the MDU, the emissions are a factor of 194,000 below the recommended maximum levels.

5. Balanced Mixer

The mixer in the MDU compares the frequency of the transmitted signal with that reflected back from targets in the coverage area. In all except the MDU2000 module, a balanced mixer configuration is used which provides superior matching and conversion loss compared with a single-ended mixer. This improves the sensitivity of the MDU, enhancing capture and reducing false alarms.

For these modules this also means that the mixer diodes are protected to a large degree from static damage since each diode protects the other from excess reverse voltages.

The mixer does not require an external DC return, however if it is desired to use a DC return (for self-test or other purposes) a value of between 1KΩ and 12KΩ is recommended. The IF output impedance of the balanced mixer is approximately 200Ω and 400Ω for the single-ended mixer.

A portion of the oscillator signal is fed to the LO (local oscillator) port of the mixer, and the return signal intercepted by the receive antenna is fed to the RF input. The magnitude of the IF output signal is proportional to the magnitude of the signal received at the RF input, and the frequency is proportional to the velocity of the target reflecting the received signal relative to the module.

Some modules are available with a pair of orthogonal (I/Q) mixers enabling the direction of motion of the moving target (towards or away from the module) to be determined.

In a real life situation there are many signals received from many different targets moving at different velocities, so the total IF output is a spectrum of signals of varying frequency and amplitude.

In addition there is a DC component at the IF output (which varies with ambient temperature), which is the vector sum of all signals reflected off static targets in the coverage area of the unit, including the housing covering the MDU. For modules with a

Using MICROWAVE SOLUTIONS Ltd. Motion Detector Units

balanced mixer this DC component is close to 0 volts and can be monitored to verify correct operation of the MDU.

6. IF Output

If the oscillator is powered continuously the IF output needs only be amplified with a narrow band low frequency amplifier covering the Doppler frequency range of interest. The Doppler frequency, which is linearly proportional to the relative velocity between the MDU and the moving target, is 70Hz per metre per second (31Hz per m.p.h.) for a microwave frequency of 10.525GHz.

If the MDU is operating in an environment where fluorescent lights are installed a narrow band notch filter will be required in the amplifier or in the subsequent signal processing to reduce the sensitivity of the unit to the moving plasma in the fluorescent tube. The frequency of this notch filter needs to be centred on twice the frequency of the line supply in the area of operation (100Hz for 50Hz supply or 120Hz for 60Hz supply).

Typical amplifier characteristics would be 70dB gain with a -3dB bandwidth of 3Hz to 80Hz, with a 60dB notch filter at twice the line frequency.

If the MDU is operated in a pulsed mode as suggested in (3) above its sensitivity will be reduced in proportion to the duty cycle of pulsing.

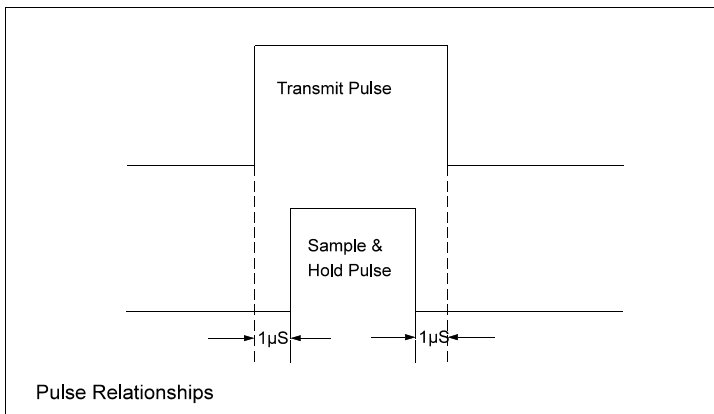

This loss of sensitivity can largely be recovered using a sample and hold circuit between the IF output of the unit and the amplifier. The sample and hold circuit would typically consist of a FET series switch turned on when the oscillator is turned on, and a shunt capacitor which is then charged from the IF output of the

unit. In practice any switching transients generated during the turn-on or turn-off of the oscillator can be eliminated from the IF output by inseting the sample and hold pulse by approximately 1µs within the oscillator pulse.

The video impedance of the IF output of the MDU is approximately 200Ω when the oscillator is running (or 400Ω for the MDU2000), and no DC return is required.

For all modules except the MDU2000, a low DC level (<± 150mV) will be present on the IF output of the MDU whilst it is operating. Under pulsed operating conditions this will appear as a square wave on the IF output, the magnitude of which will vary with the mounting location of the unit and with static reflecting targets in its coverage area. This voltage is the vector sum of a large number of reflected signals from both within the MDU and the environment in which it is operating. It will also vary as a function of ambient temperature.

Using MICROWAVE SOLUTIONS Ltd. Motion Detector Units

As long as this DC level is less than $\pm 150\text{mV}$ under all operating conditions the functional performance of the unit will be within specification. If external DC bias is applied to the IF output this should be such that the DC level does not fall outside these limits.

For the MDU2000, the DC level on the IF output will be between $+1.0\text{V}$ and $+2.0\text{V}$ when it is operating. Under pulsed operating conditions this will appear as a square wave on the IF output and appropriate provision must be made in the sample & hold and amplifier circuitry to eliminate this signal.

7. Coverage Pattern

The MDU uses separate transmit and receive antennas. As well as improving the sensitivity of the unit by providing isolation between transmit and receive paths this feature also permits the shape of the coverage pattern to be optimised.

The coverage pattern of the standard unit is 72° horizontally and 36° vertically, with the connection tab facing downwards. This represents the angular coverage over which the sensitivity is at least 70% of the peak sensitivity directly in front of the MDU.

In practice, in an intruder alarm sensor, this equates to a horizontal coverage pattern of 90° so that a unit mounted in the corner of a rectangular room will give complete coverage along the walls without unprotected creep zones.

Other patterns, including a 360° coverage for use in a ceiling mounted application, are also available. Consult Microwave Solutions Ltd. or visit our website for further details.

8. Mounting Arrangements

The MDU must be mounted firmly as movement relative to a fixed object within the coverage pattern will provide a Doppler output which could be detected as a target. Mounting points are provided on the MDU, which should be used to attach the unit firmly to the sensor. There should be no obstruction in front of the unit or within a 45° arc from the edges of the unit that is closer than 6mm from the face. Beyond this distance a plastic (ABS, polyethylene, PVC etc) window can be mounted, through which the microwave signal will be transmitted. The thickness of this window will affect the sensitivity of the unit, although for the plastics mentioned above a 2mm thick window would be expected to reduce range by less than 10%.

9. Connections

The length of leads connecting the MDU to the signal processing circuitry must be minimised, to reduce pick up of electromagnetic interference. A maximum lead length of 1.5cm is recommended and screened leads are preferred. The housing of the unit can be grounded, but the electrical ground connection must be made through the GND tab. Some of the units are also equipped with connection points in the four corners of the module, that can be used to mechanically mount the unit as well as provide electrical connections. This method of connection is not recommended for high security applications, since the unit is more susceptible to interference from external RF fields when connected in this manner.

Using MICROWAVE SOLUTIONS Ltd. Motion Detector Units

The unit is susceptible to static damage, so normal static handling procedures must be adopted when connecting or testing the units. In general, susceptibility to static damage is much reduced once the MDU is connected to the rest of the electronics.

10. Outline Drawings

Basic outline drawings for the different versions of the MDU are shown below. Fully detailed drawings are available in .pdf or .dwg format from our website or on request.

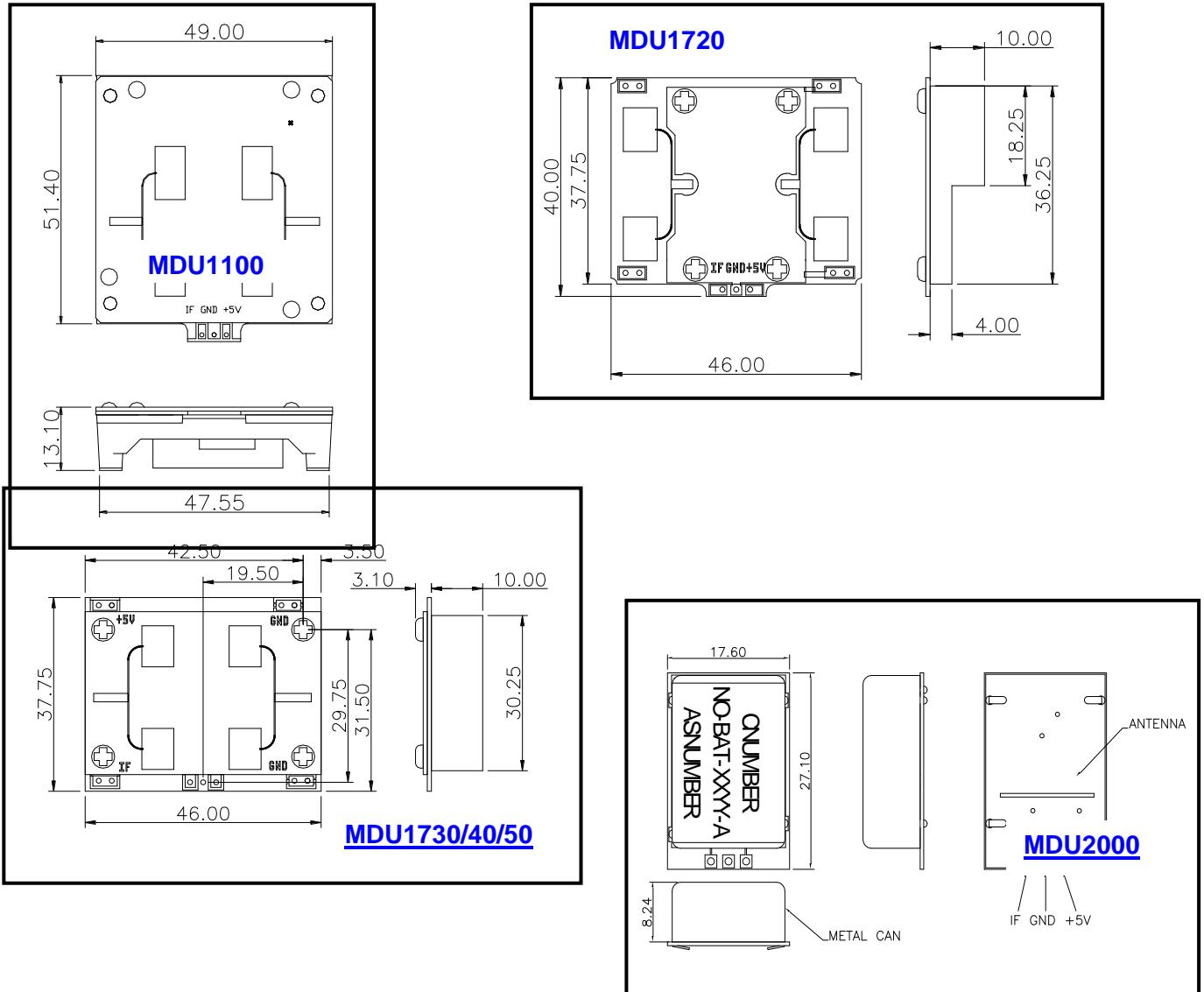

Using MICROWAVE SOLUTIONS Ltd. Motion Detector Units

Appendix 1

RADAR RANGE EQUATION & CALCULATION OF RANGE

The MDU is a Doppler Radar System and as such its performance is described by the Radar Range Equation. This equation relates the characteristics of the MDU (such as transmit power, antenna size, receive sensitivity, frequency) and the target (size, distance, reflectivity) to the range available from an intruder alarm detector. A detailed derivation of this equation can be found in any standard radar text book. If we have available an amount of power P_t (Watts) which is transmitted uniformly in all directions, the power density P_d (Watts/sq. Metre) at a distance R (Metres) from the transmitter is given by the formula :-

$$P_d = \frac{P_t}{4\pi R^2}$$

The MDU has a directional antenna, which concentrates the transmitted power in the required direction. This increases the power density in this direction by the gain of the antenna G (dBi). Thus the power density in our case is :-

$$P_d = G \frac{P_t}{4\pi R^2}$$

This energy hits our target and most of it is absorbed or scattered. Some of it gets reflected back towards the MDU. How much depends on the size, shape and material of the target and is expressed as the size of a flat metal reflector which would give the same reflected signal as our target. This size, called the "radar cross section" of the target, σ (Metres²) is approximately 1M² for a human target. The power reflected from our target is therefore :-

$$P_r = \sigma G \frac{P_t}{4\pi R^2}$$

This power, which is transmitted in all directions, gives a power density back at the MDU of :-

$$P_d = \frac{1}{4\pi R^2} \sigma G \frac{P_t}{4\pi R^2}, \text{ simplifying to :-}$$

$$P_d = P_t \sigma G \frac{1}{[4\pi R^2]^2}$$

If the area of the receive antenna is A , the power incident on the receiver P_r is given by :-

$$P_r = AP_t \sigma G \frac{1}{[4\pi R^2]^2}$$

The gain of an antenna G can also be expressed in terms of its aperture size A and the wavelength of the received signal λ using the equation :-

$$G = \frac{4\pi A}{\lambda^2}$$

By substitution in the previous equation the received power becomes :-

$$P_r = \frac{G^2 \lambda^2 P_t \sigma}{[4\pi]^3 R^4}$$

Using the following values :-

Gain	G	=	8dBi	(6.13)
Wavelength	λ	=	2.85cm	(.0285)
Transmit Power	P_t	=	25mW	(.025)

the received power becomes :-

$$P_r = \frac{3.845 \times 10^{-7}}{R^4} \text{ Watts}$$

The maximum sensitivity of the MDU is -90dBm (equivalent to 10^{-12} Watts) which gives a theoretical range of 25 metres. A typical MDU with state-of-the-art signal processing will achieve a range of 20 metres (equivalent sensitivity -86dBm).